

# VESTA

F I T N E S S

ASSEMBLY MANUAL

VTA24001  
POWER RACK

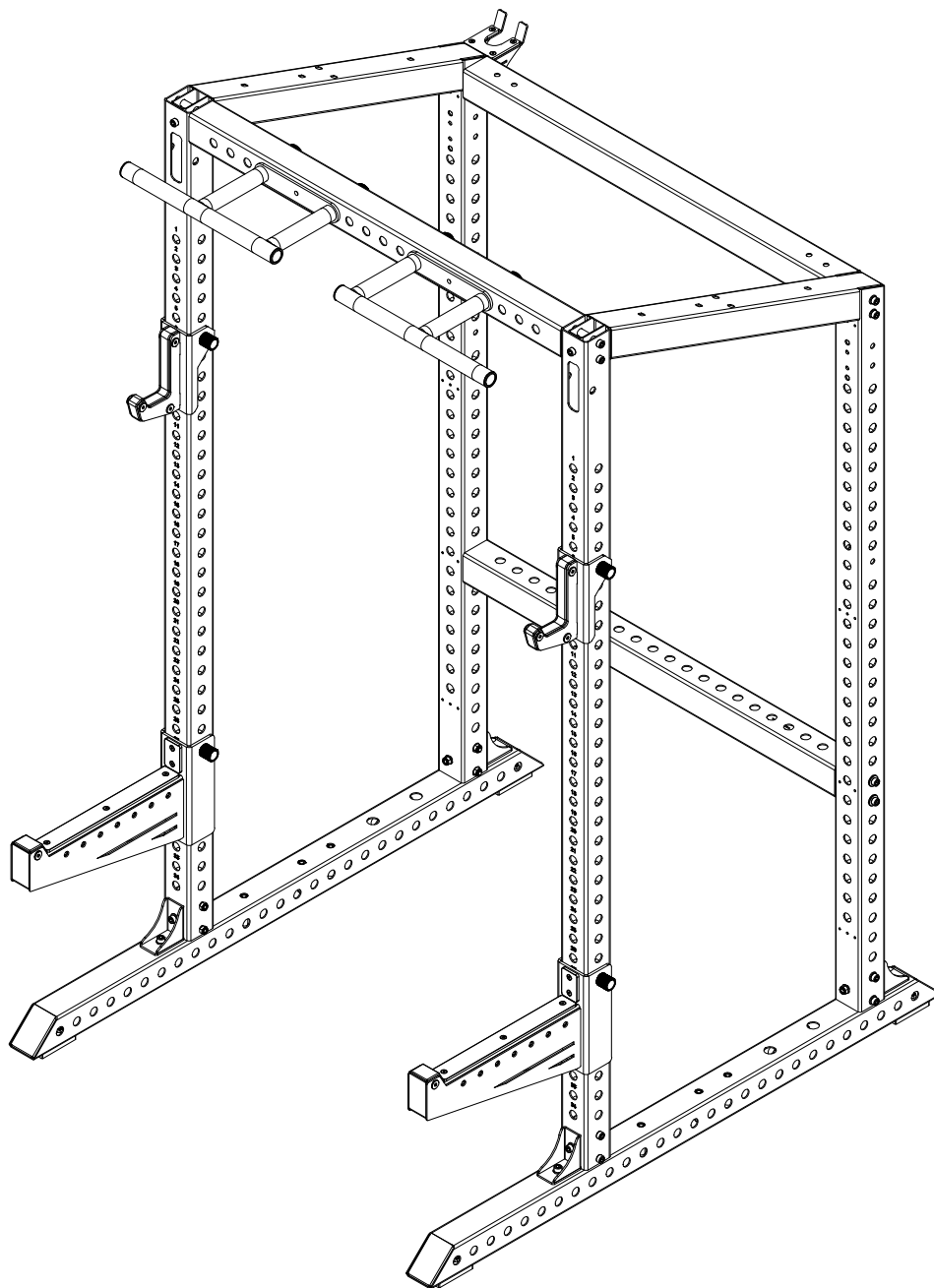

## CAUTION!

Read all precautions and instructions in this manual before using this equipment.

20241025-V1.0

## **IMPORTANT SAFETY NOTICE**

### **PRECAUTIONS**

This exercise machine is built for optimum safety. However, certain precautions apply whenever you operate a piece of exercise equipment. Be sure to read the entire manual before you assemble or operate your machine. In particular, note the following safety precautions:

1. **Keep children and pets away from the machine at all times. DO NOT leave children unattended in the same room with the machine.**
2. Only one person at a time should use the machine.
3. If the user experiences dizziness, nausea, chest pain, or any other abnormal symptoms, STOP the workout at once. CONSULT A PHYSICIAN IMMEDIATELY.
4. Position the machine on a clear, leveled surface. DO NOT use the machine near water or outdoors.
5. Keep hands away from all moving parts.
6. Always wear appropriate workout clothing when exercising. DO NOT wear robes or other clothing that could become caught in the machine. Running or aerobic shoes are also required when using the machine.
7. Use the machine only for its intended use as described in this manual. DO NOT use attachments not recommended by the manufacturer.
8. Do not place any sharp object around the machine.
9. Disabled person should not use the machine without a qualified person or physician in attendance.
10. Before using the machine to exercise, always do stretching exercises to properly warm up.
11. Never operate the machine if the machine is not functioning properly.

**WARNING: BEFORE BEGINNING ANY EXERCISE PROGRAM, CONSULT YOUR PHYSICIAN. THIS IS ESPECIALLY IMPORTANT FOR INDIVIDUALS OVER THE AGE OF 35 OR PERSONS WITH PRE-EXISTING HEALTH PROBLEMS. READ ALL INSTRUCTIONS BEFORE USING ANY FITNESS EQUIPMENT. WE ASSUME NO RESPONSIBILITY FOR PERSONAL INJURY OR PROPERTY DAMAGE SUSTAINED BY OR THROUGH THE USE OF THIS PRODUCT.**

**SAVE THESE INSTRUCTIONS.**

Assembly Dimension:1505×1315×2200

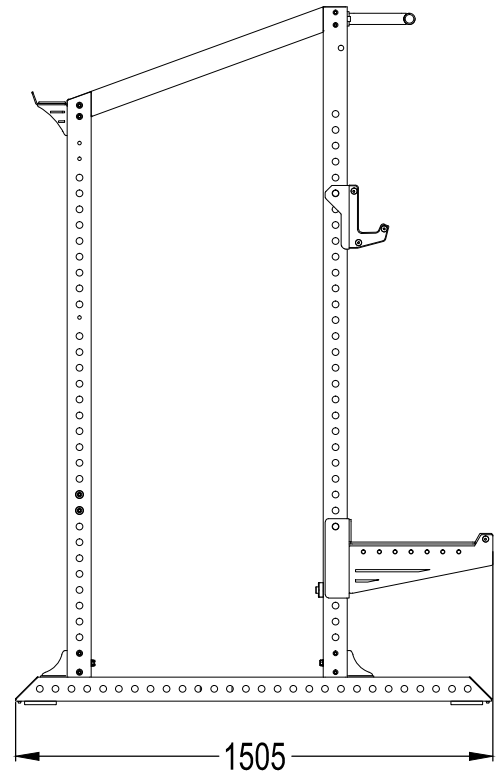
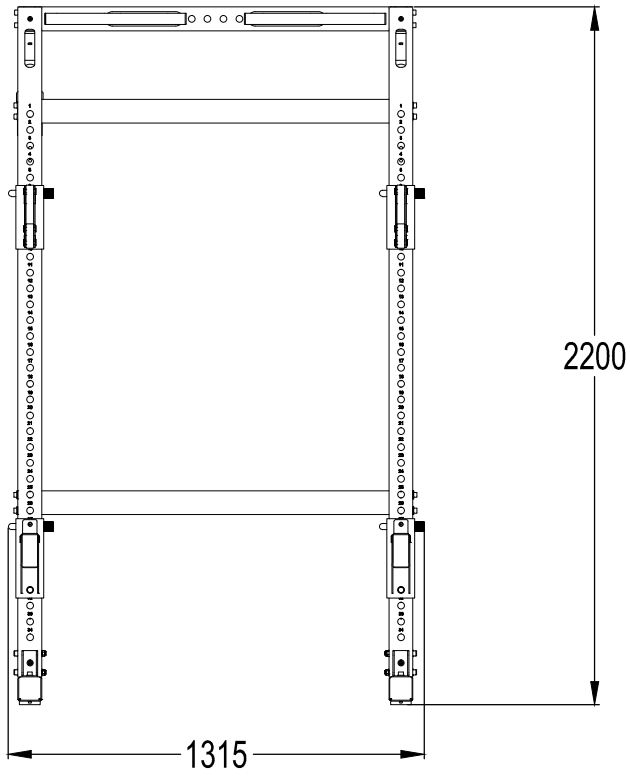

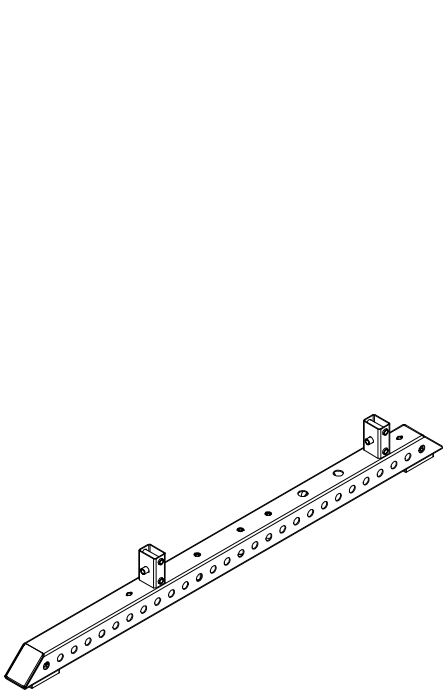

① × 2



④ × 2

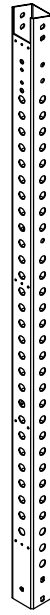

⑤ × 2

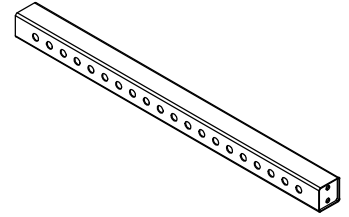

⑦ × 1

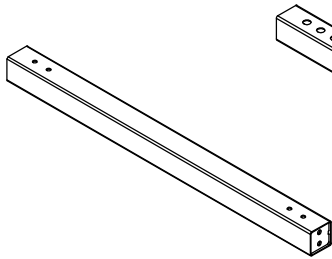

⑧ × 1

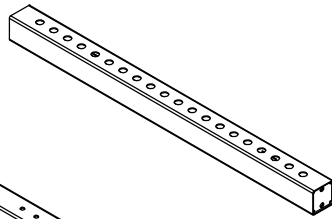

⑨ × 1

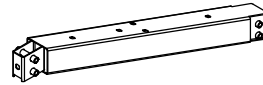

⑩ × 2

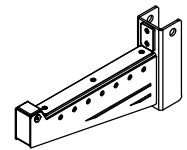

⑬ × 2

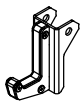

⑭ × 2

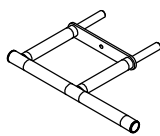

⑰ × 2



⑳ × 4



㉔ × 1



㉗ × 4



⑬ × 6



⑰ × 4

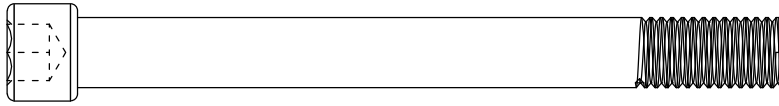

110 ×4

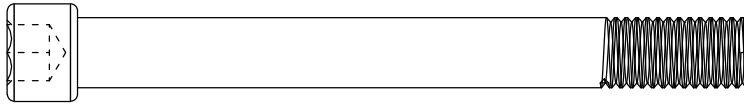

111 ×14

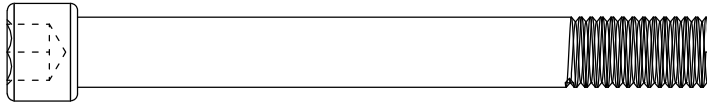

112 ×4

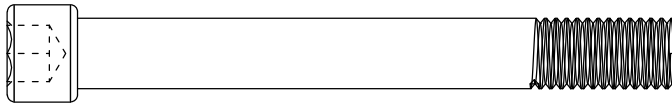

113 ×4

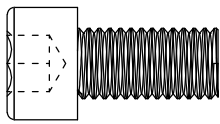

120 ×7

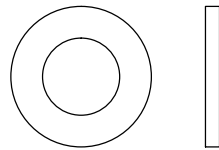

139 ×27

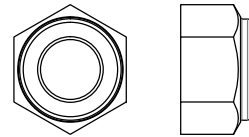

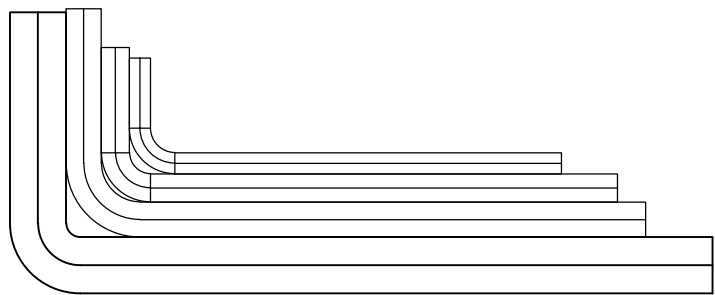

146 ×12



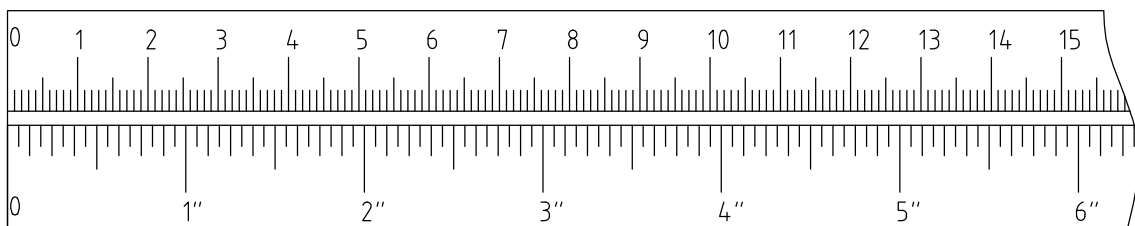

3#×1  
4#×1  
5#×1  
8#×1

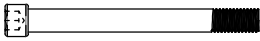
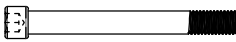
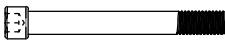
mm





- ①①①  ×2 M10×100mm
- ①①②  ×4 M10×90mm
- ①①③  ×4 M10×85mm
- ①②①  ×3 M10×20mm

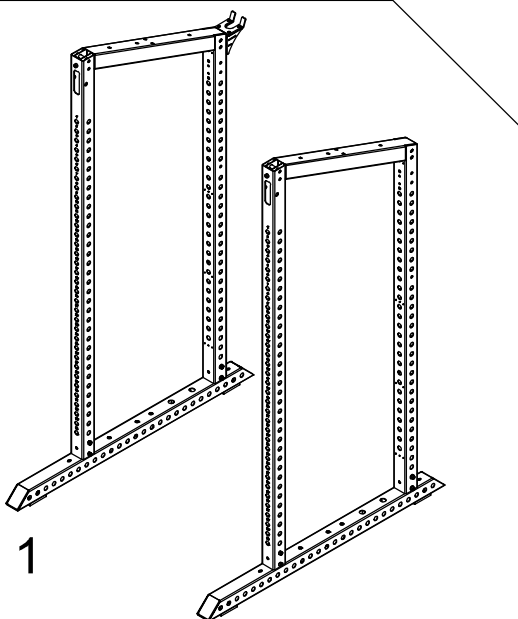
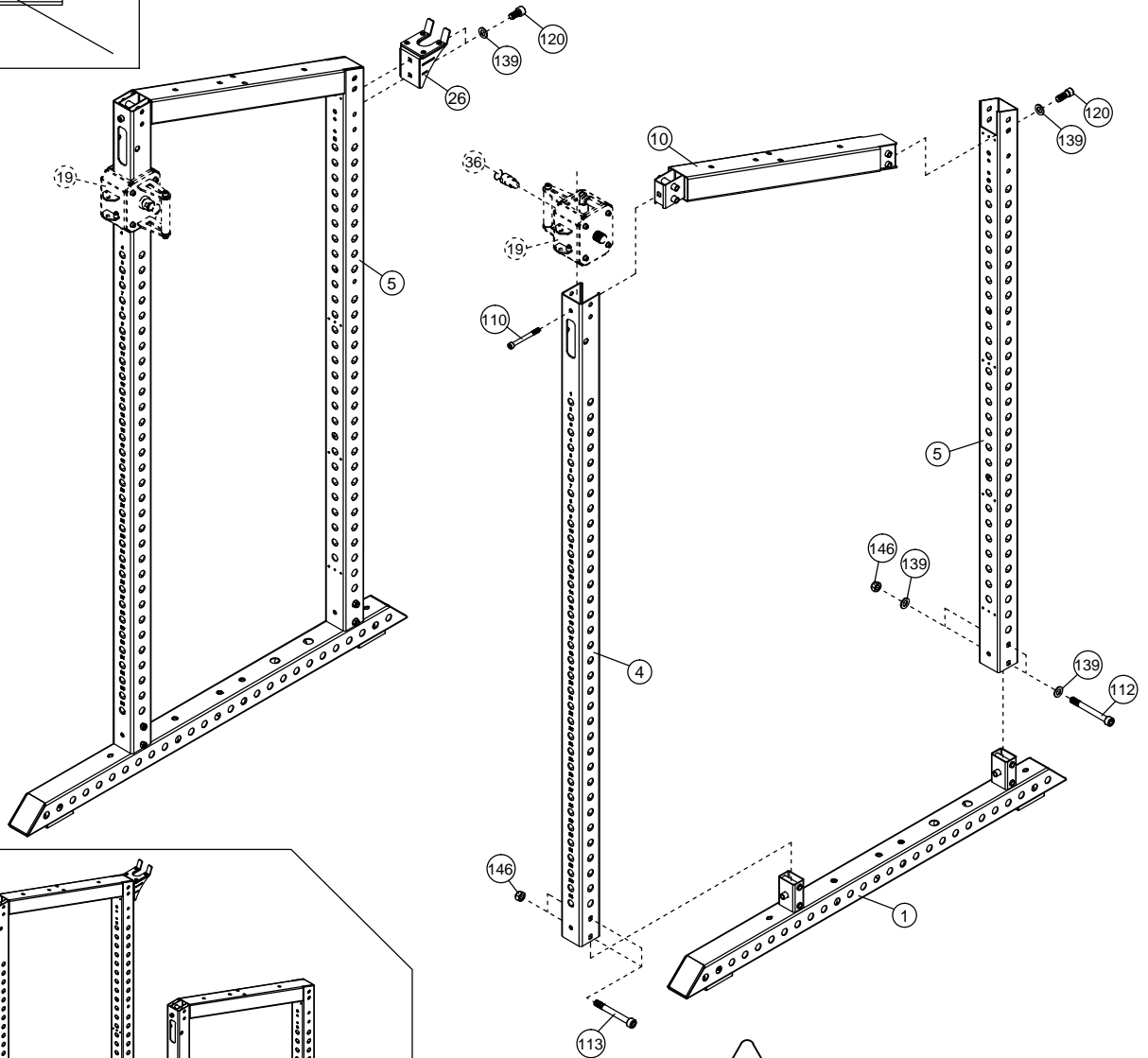
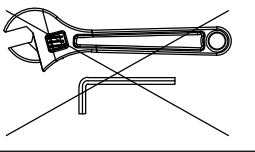

- ①③⑨  ×11 φ20×φ10.5
- ①④⑥  ×8 M10

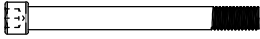

If you purchased VTA24004, please install #19 and #36 in this step.

VTA24004 (dual adjustable pulley with weight stack )

- ①10  ×2 M10×100mm
- ①11  ×2 M10×95mm
- ①20  ×4 M10×20mm

- ①39  ×12 φ20×φ10.5
- ①46  ×4 M10

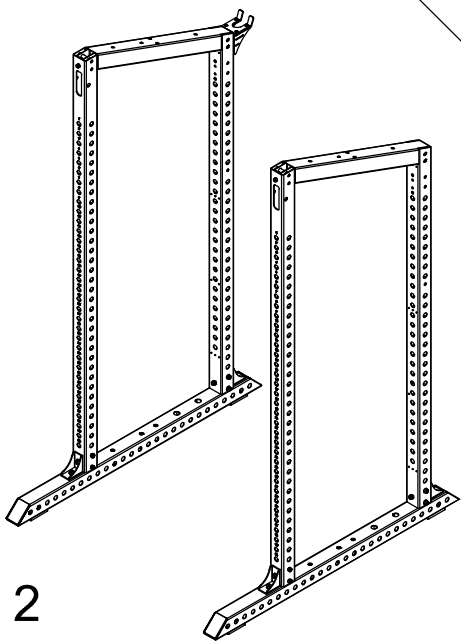
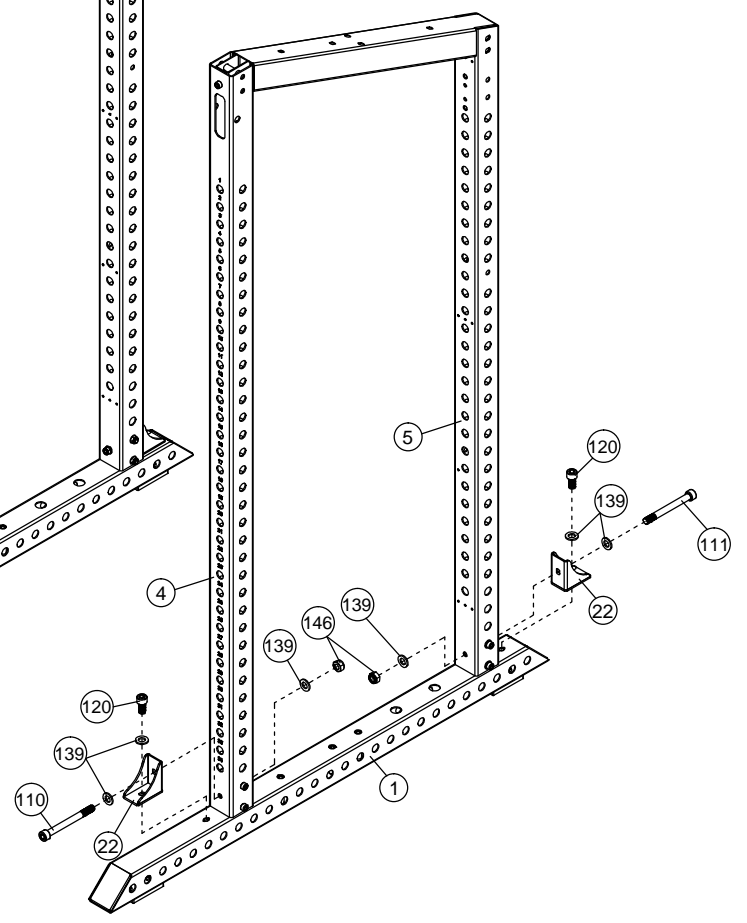
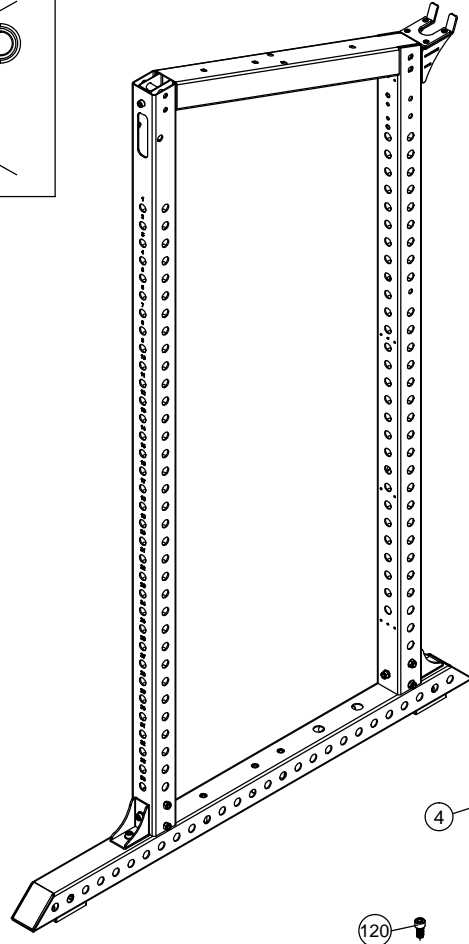
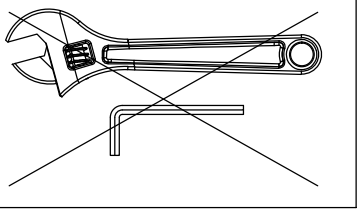

111

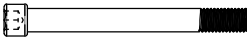

×12 M10×95mm

139



×4 φ20×φ10.5

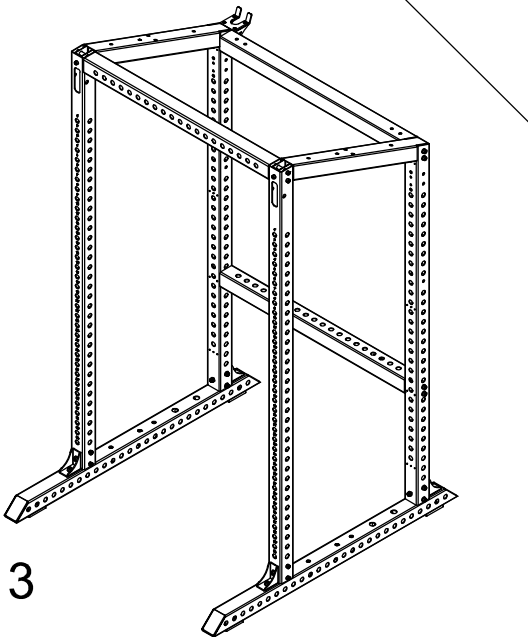
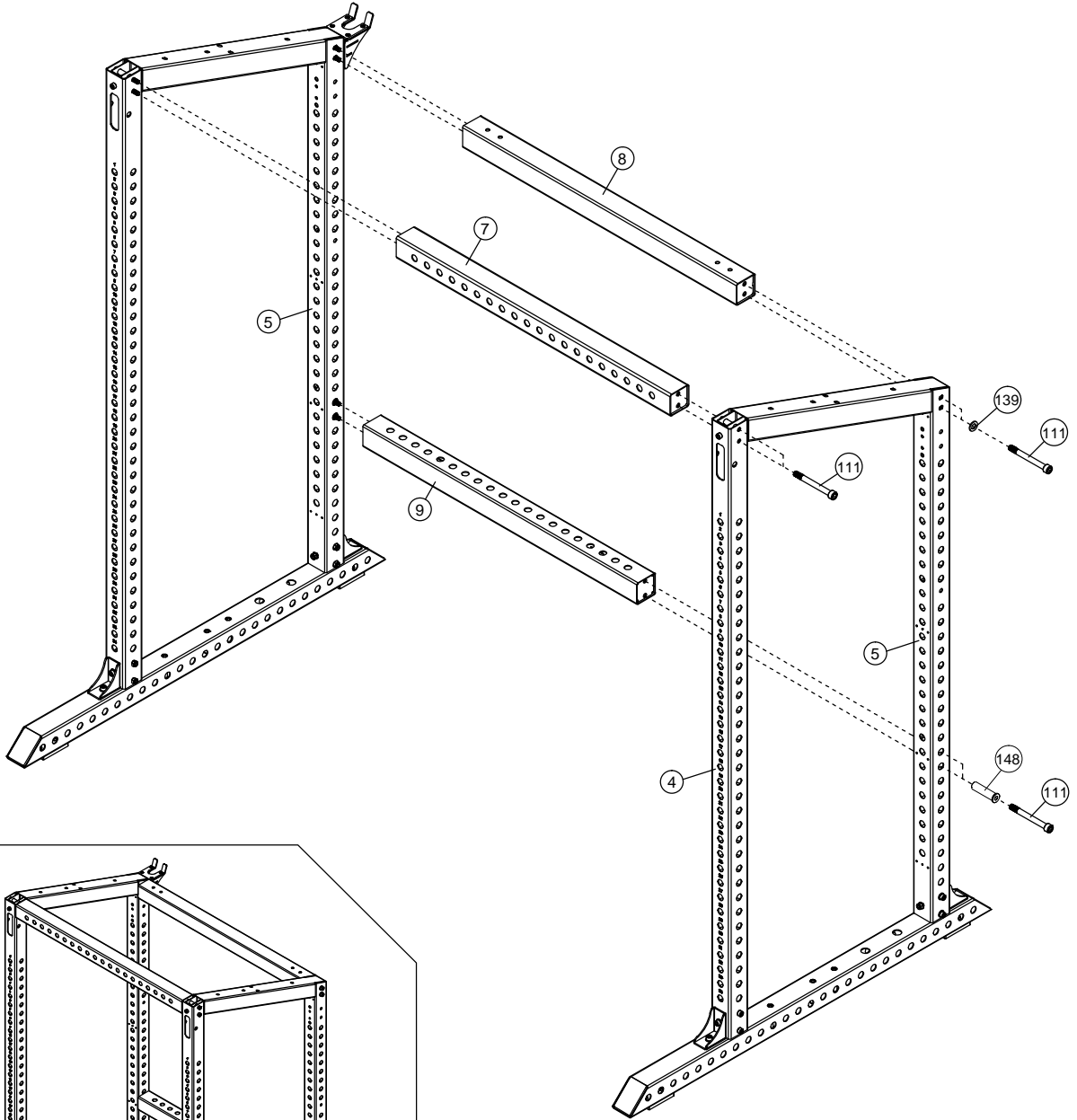
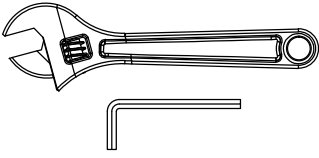

3

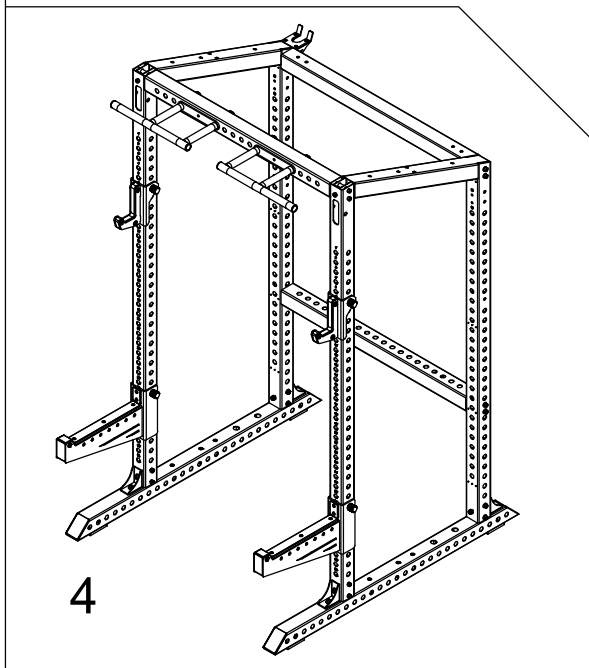
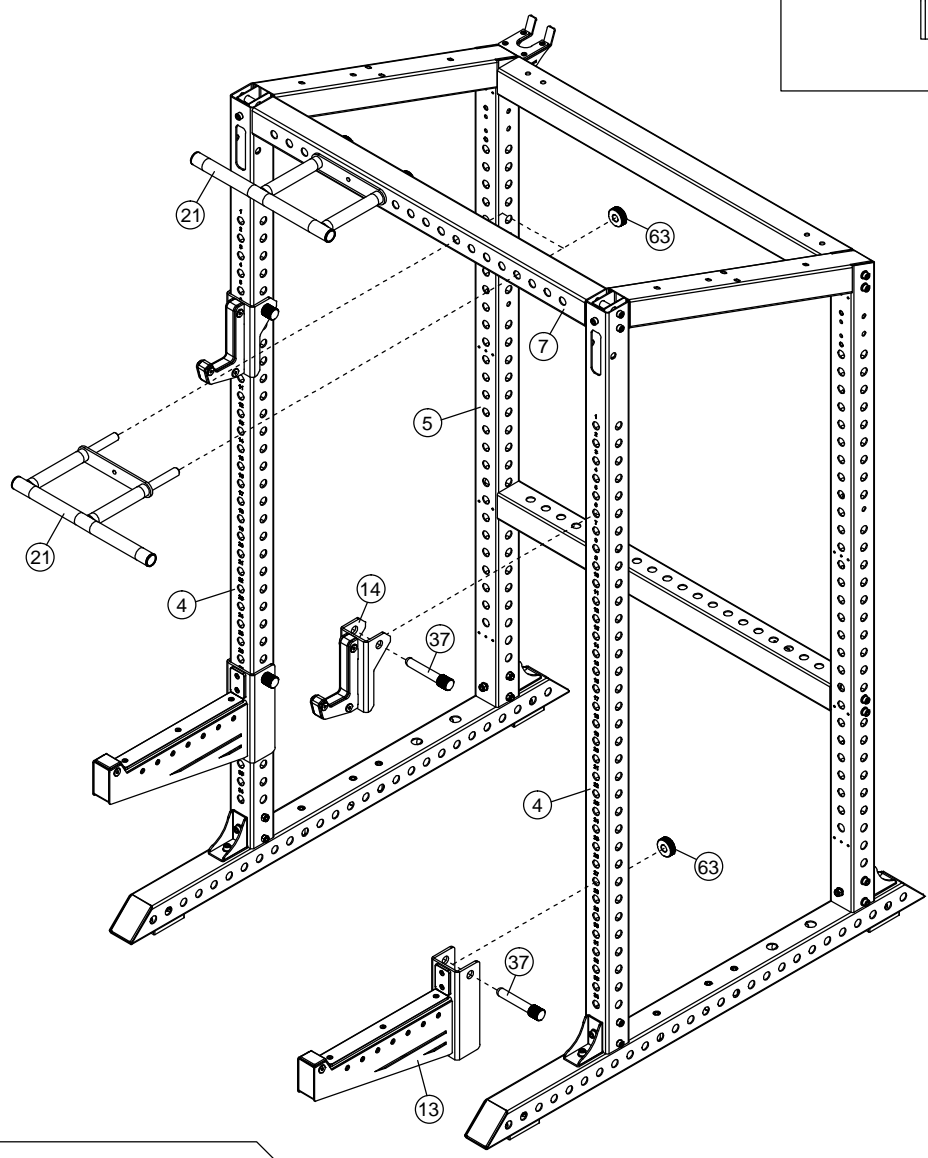
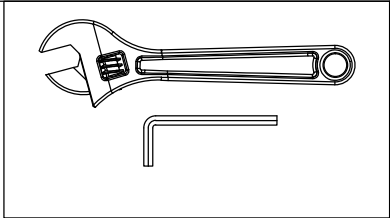

If you purchased VTA24001 or VTA24004, please do not tighten the screws in this step.

VTA24001 ( middle support for smith or weight stack shrouds)  
VTA24004 (dual adjustable pulley with weight stack )

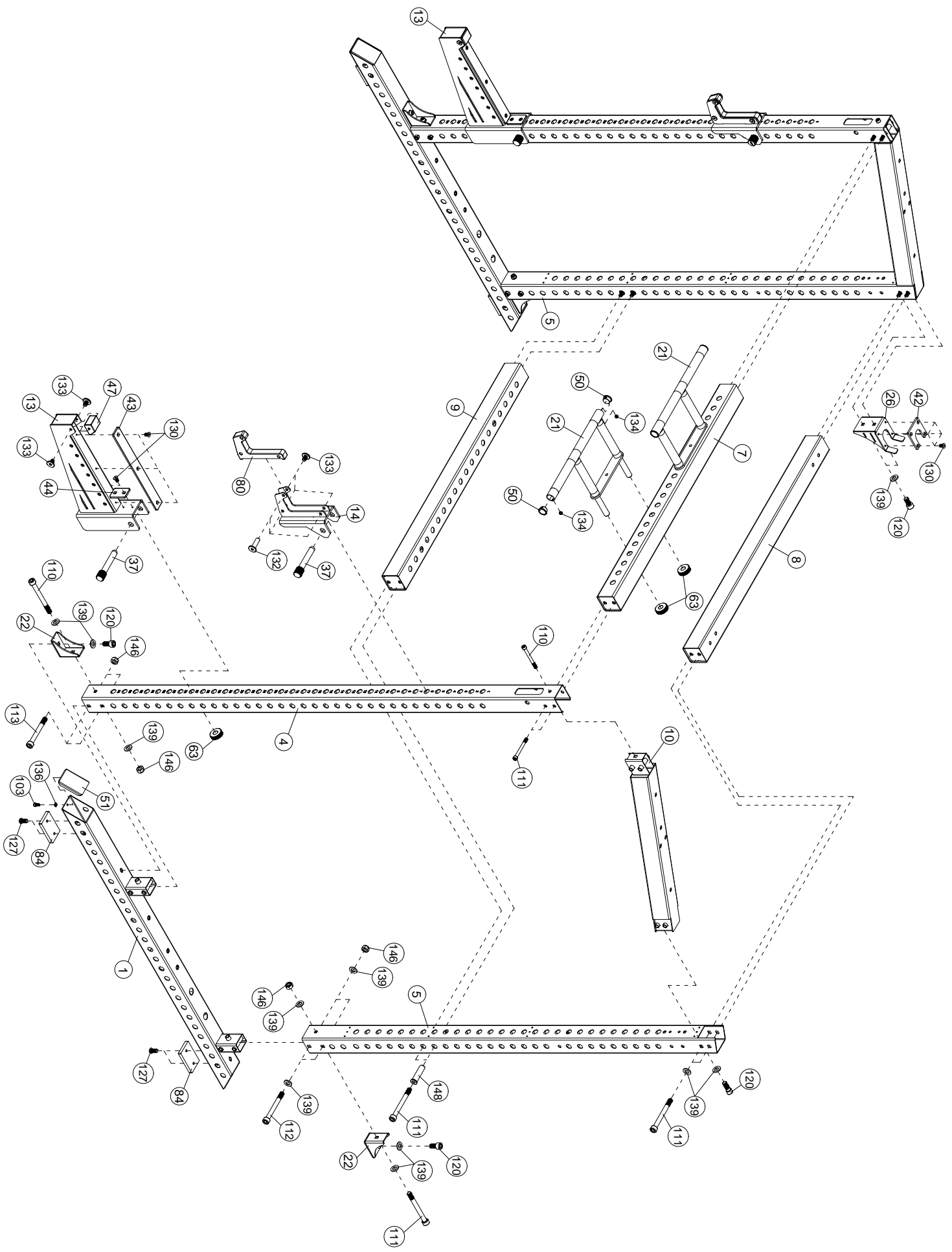

# VTA24001 PARTS LIST

KEY NO.	PART DESCRIPTION	SPEC	QTY
1	Base Frame		2
4	Front Sliding Frame		2
5	Stand Frame		2
7	Connecting Frame Rear		1
8	Connecting Frame Rear		1
9	Connecting Frame Rear		1
10	Upper Connecting Frame		2
13	Long Safety Rack		2
14	Short Safety		2
21	Handle		2
22	Small Reinforcing Frame		4
26	Barbell Bar Hanger		1
37	Aluminum Alloy Bolt		4
42	Rack Liner	85×84×6	1
43	Rack Liner	390×45×6	2
44	Rack Liner	70×45×6	2
47	Nylon Block	52×33×49	2
50	Aluminum Trim Cover	φ35×φ30×15	4
51	Angled Cover	□75×2.5 (45°)	4
63	Knurled Nut	φ45×15×M20	6
80	Safety Hook	199×125×25	2
84	Rubber Stopper	65×100×12	4
103	Hexagon socket button head screws	M5×10	4
110	Hexagon socket button head screws	M10×100	4
111	Hexagon socket button head screws	M10×95	14
112	Hexagon socket button head screws	M10×90	4
113	Hexagon socket button head screws	M10×85	4
120	Hexagon socket button head screws	M10×20	7
127	Allen Bolt	M8×16	8
130	Hexagon socket countersunk head screws	M6×10	14
132	Allen Bolt	φ20×φ10×M8×32	6
133	Allen Bolt	φ20×M8×12	10
134	Set Screw	M6×6	4
136	Washer	5	4
139	Washer	10	27
146	Nut	M10	12
148	Bushing	φ25×φ20×φ10.2×77.5	4

PARTS LIST

KEY NO.	PART DESCRIPTION	SPEC	QTY
	Allen Wrench	3#	1
	Allen Wrench	4#	1
	Allen Wrench	5#	1
	Allen Wrench	8#	1

# VESTA

F I T N E S S

ASSEMBLY MANUAL

VTA24002

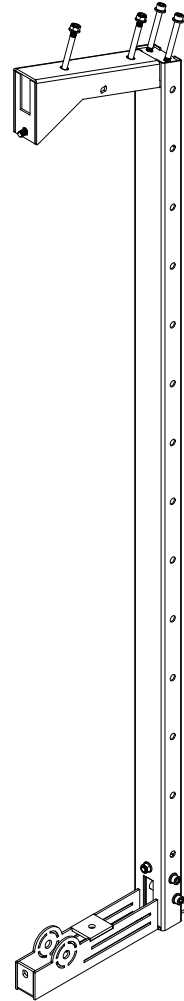
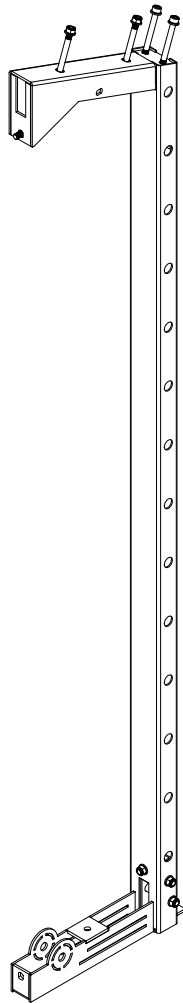

## CAUTION!

Read all precautions and instructions in this manual before using this equipment.

## **IMPORTANT SAFETY NOTICE**

### **PRECAUTIONS**

This exercise machine is built for optimum safety. However, certain precautions apply whenever you operate a piece of exercise equipment. Be sure to read the entire manual before you assemble or operate your machine. In particular, note the following safety precautions:

1. **Keep children and pets away from the machine at all times. DO NOT leave children unattended in the same room with the machine.**
2. Only one person at a time should use the machine.
3. If the user experiences dizziness, nausea, chest pain, or any other abnormal symptoms, STOP the workout at once. CONSULT A PHYSICIAN IMMEDIATELY.
4. Position the machine on a clear, leveled surface. DO NOT use the machine near water or outdoors.
5. Keep hands away from all moving parts.
6. Always wear appropriate workout clothing when exercising. DO NOT wear robes or other clothing that could become caught in the machine. Running or aerobic shoes are also required when using the machine.
7. Use the machine only for its intended use as described in this manual. DO NOT use attachments not recommended by the manufacturer.
8. Do not place any sharp object around the machine.
9. Disabled person should not use the machine without a qualified person or physician in attendance.
10. Before using the machine to exercise, always do stretching exercises to properly warm up.
11. Never operate the machine if the machine is not functioning properly.

**WARNING: BEFORE BEGINNING ANY EXERCISE PROGRAM, CONSULT YOUR PHYSICIAN. THIS IS ESPECIALLY IMPORTANT FOR INDIVIDUALS OVER THE AGE OF 35 OR PERSONS WITH PRE-EXISTING HEALTH PROBLEMS. READ ALL INSTRUCTIONS BEFORE USING ANY FITNESS EQUIPMENT. WE ASSUME NO RESPONSIBILITY FOR PERSONAL INJURY OR PROPERTY DAMAGE SUSTAINED BY OR THROUGH THE USE OF THIS PRODUCT.**

**SAVE THESE INSTRUCTIONS.**



② × 1



③ × 1

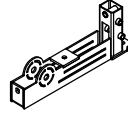

⑫ × 2

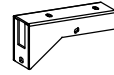

⑳ × 2

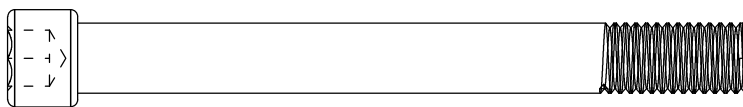

111 x4

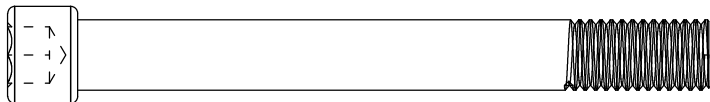

112 x4

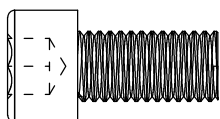

120 x8

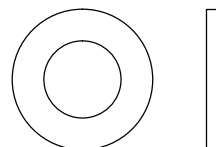

139 x28

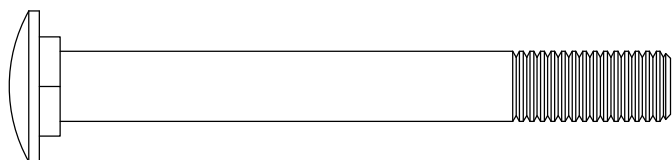

121 x4

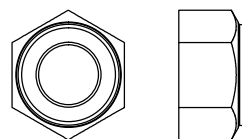

146 x10

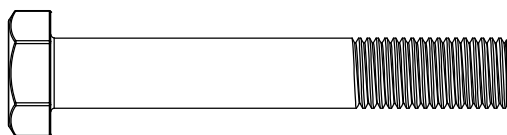

122 x2



8#x1

mm

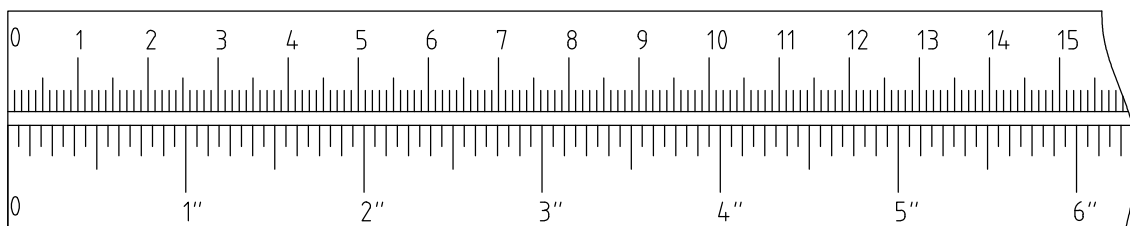



①①② M10×90mm ×4

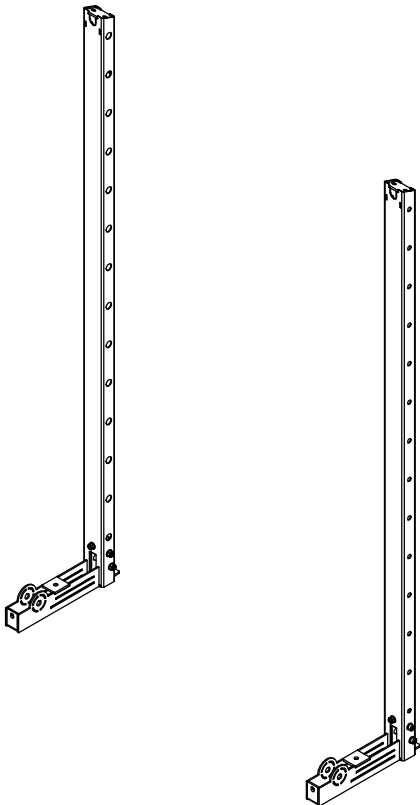
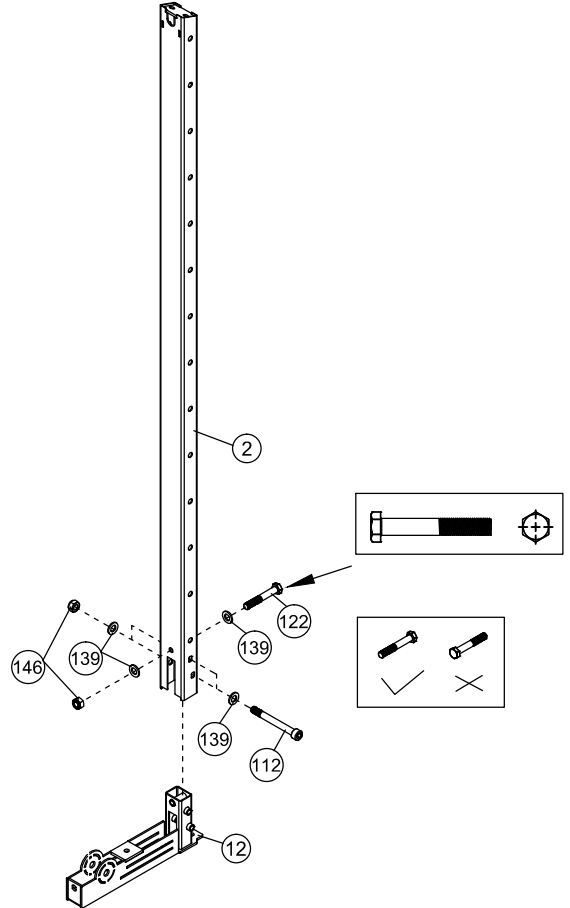
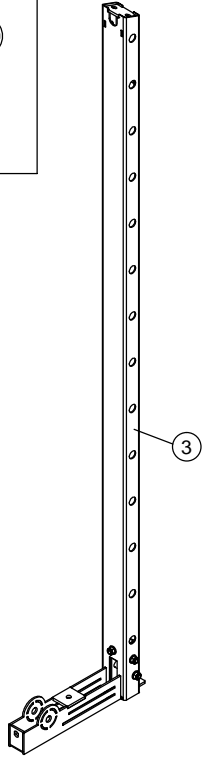
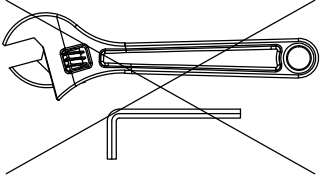

①③⑨ φ20×φ10.5 × 12

①②② M10×65mm ×2

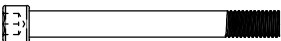
①④⑥ M10 × 6

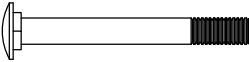

- ①11  ×4 M10×95mm
- ①20  ×8 M10×20mm
- ①21  ×4 M10×90mm

- ①39  × 16 φ20×φ10.5
- ①46  × 4 M10

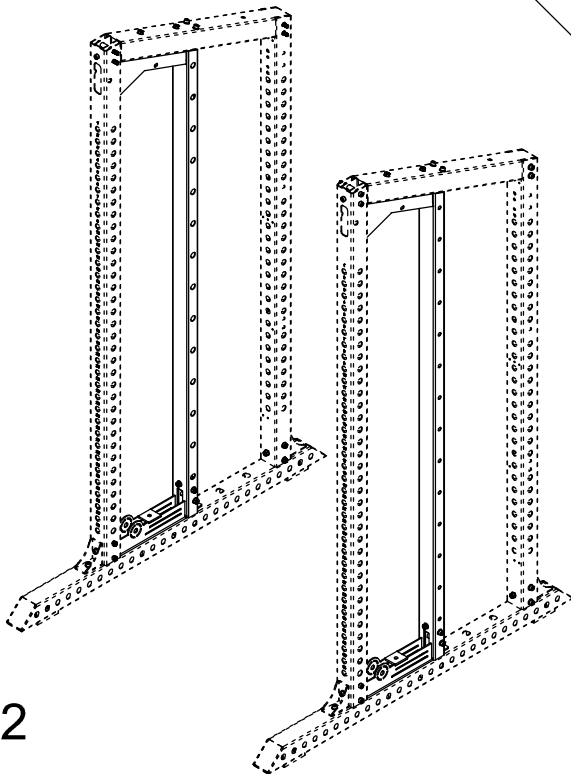
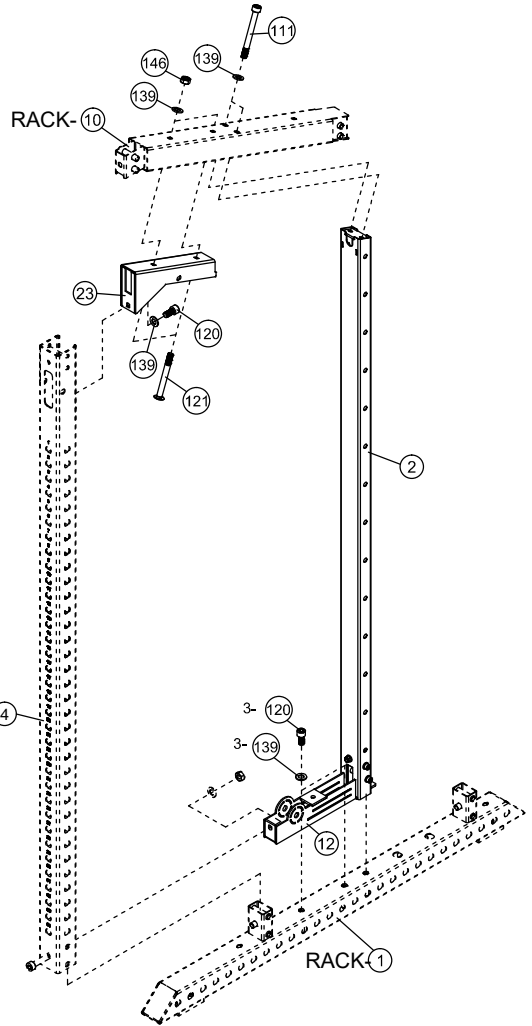
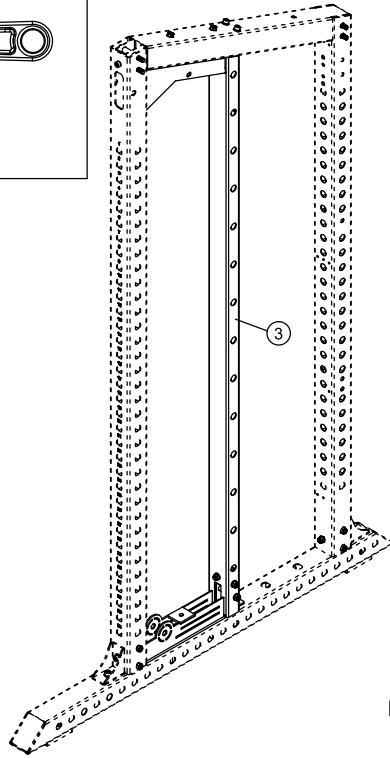
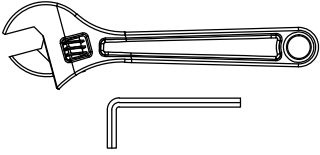

2

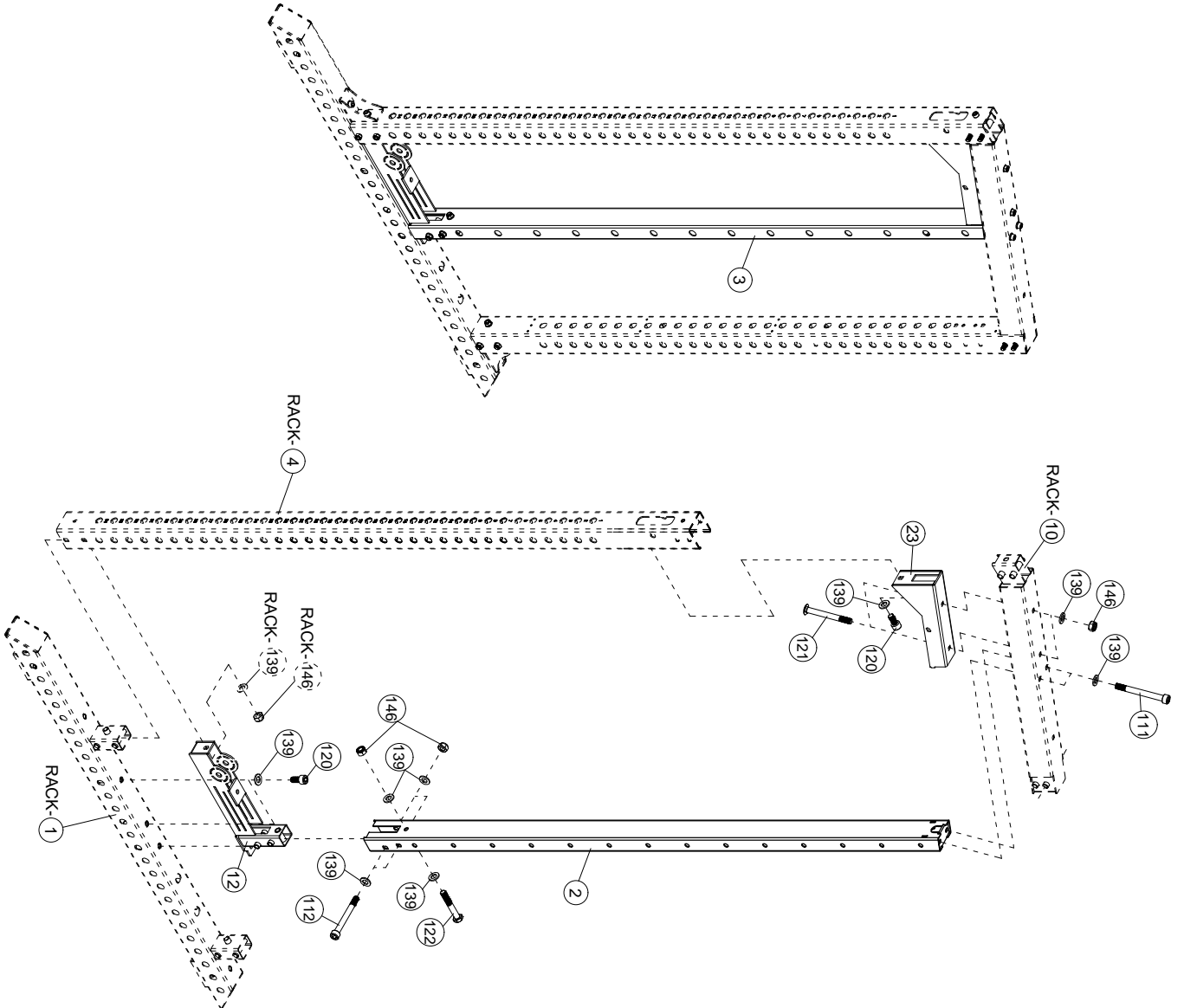

## VTA24002 PARTS LIST

KEY NO.	PART DESCRIPTION	SPEC	QTY
2	Intermediate Stand L		1
3	Intermediate Stand R		1
12	Bottom Pulley Frame		2
23	Reinforcing Frame		2
111	Hexagon socket button head screws	M10×95	4
112	Hexagon socket button head screws	M10×90	4
120	Hexagon socket button head screws	M10×20	8
121	Carriage Bolt	M10×90	4
122	Hex Bolt	M10×65	2
139	Washer	10	28
146	Nut	M10	10
	Allen Wrench	8#	1

# VESTA

F I T N E S S

ASSEMBLY MANUAL

VTA24003

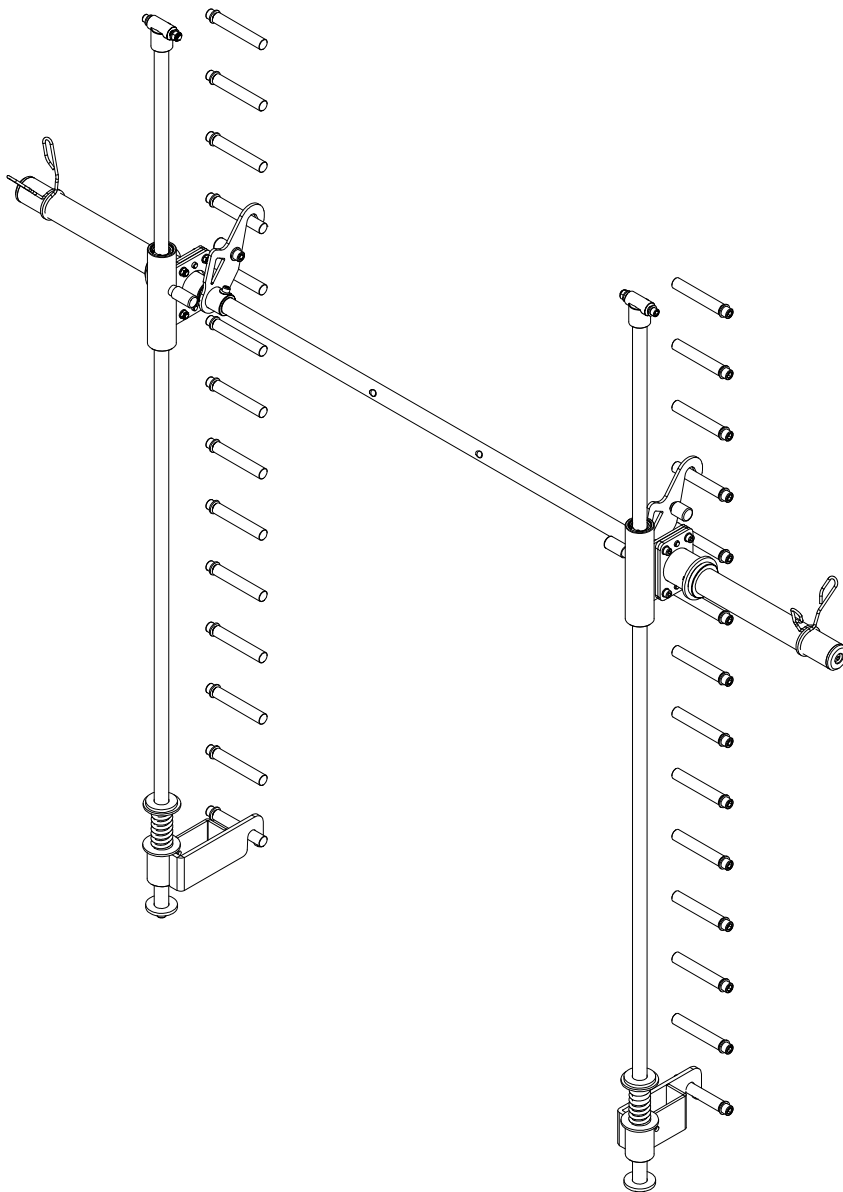

## CAUTION!

Read all precautions and instructions in this manual before using this equipment.

20240812-V1.0

## **IMPORTANT SAFETY NOTICE**

### **PRECAUTIONS**

This exercise machine is built for optimum safety. However, certain precautions apply whenever you operate a piece of exercise equipment. Be sure to read the entire manual before you assemble or operate your machine. In particular, note the following safety precautions:

1. **Keep children and pets away from the machine at all times. DO NOT leave children unattended in the same room with the machine.**
2. Only one person at a time should use the machine.
3. If the user experiences dizziness, nausea, chest pain, or any other abnormal symptoms, STOP the workout at once. CONSULT A PHYSICIAN IMMEDIATELY.
4. Position the machine on a clear, leveled surface. DO NOT use the machine near water or outdoors.
5. Keep hands away from all moving parts.
6. Always wear appropriate workout clothing when exercising. DO NOT wear robes or other clothing that could become caught in the machine. Running or aerobic shoes are also required when using the machine.
7. Use the machine only for its intended use as described in this manual. DO NOT use attachments not recommended by the manufacturer.
8. Do not place any sharp object around the machine.
9. Disabled person should not use the machine without a qualified person or physician in attendance.
10. Before using the machine to exercise, always do stretching exercises to properly warm up.
11. Never operate the machine if the machine is not functioning properly.

**WARNING: BEFORE BEGINNING ANY EXERCISE PROGRAM, CONSULT YOUR PHYSICIAN. THIS IS ESPECIALLY IMPORTANT FOR INDIVIDUALS OVER THE AGE OF 35 OR PERSONS WITH PRE-EXISTING HEALTH PROBLEMS. READ ALL INSTRUCTIONS BEFORE USING ANY FITNESS EQUIPMENT. WE ASSUME NO RESPONSIBILITY FOR PERSONAL INJURY OR PROPERTY DAMAGE SUSTAINED BY OR THROUGH THE USE OF THIS PRODUCT.**

**SAVE THESE INSTRUCTIONS.**

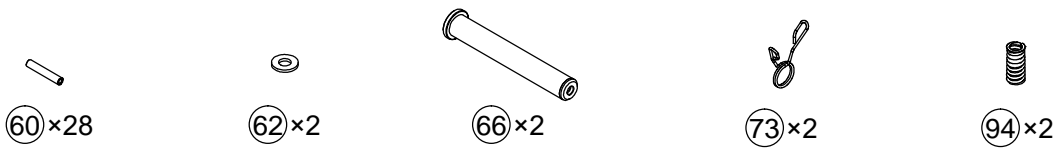
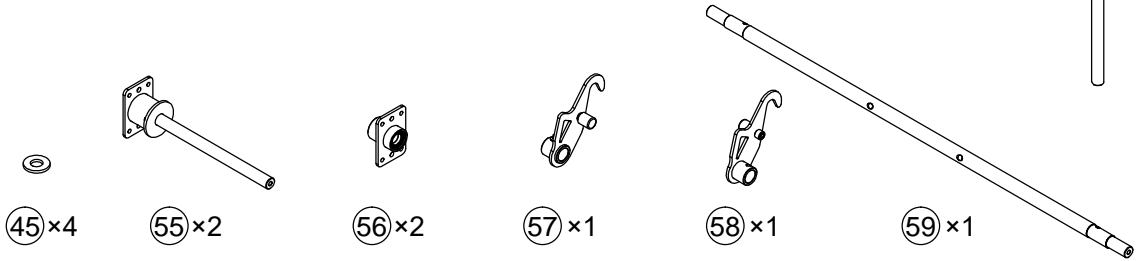
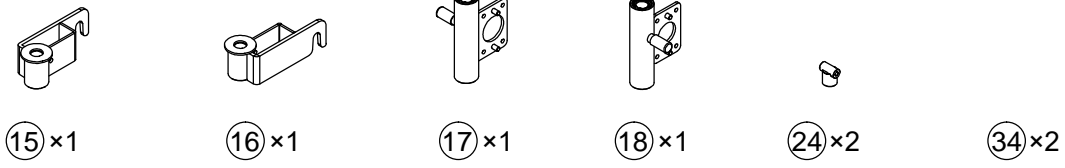



107 × 2

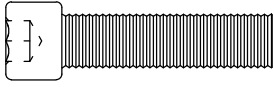

108 × 8

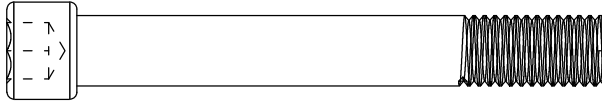

114 × 2

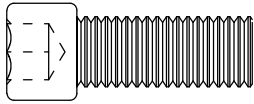

119 × 2

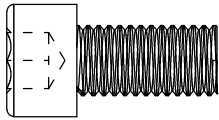

120 × 2

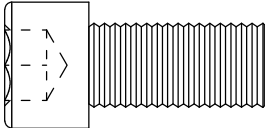

125 × 28

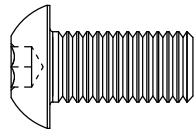

128 × 2



135 × 2

mm

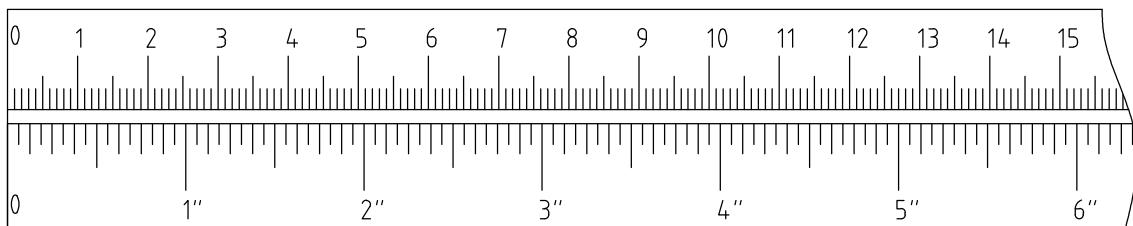

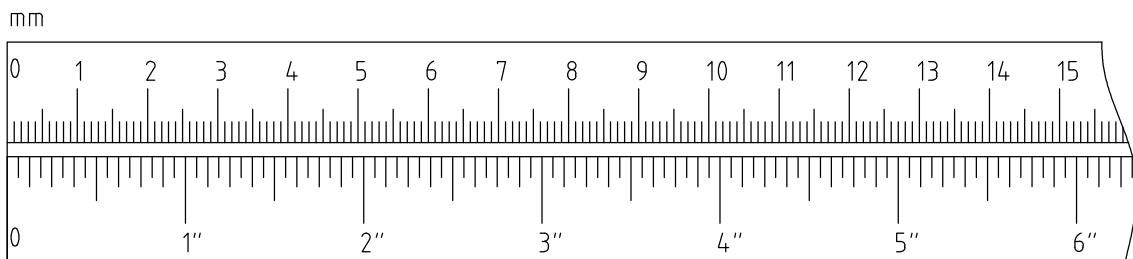
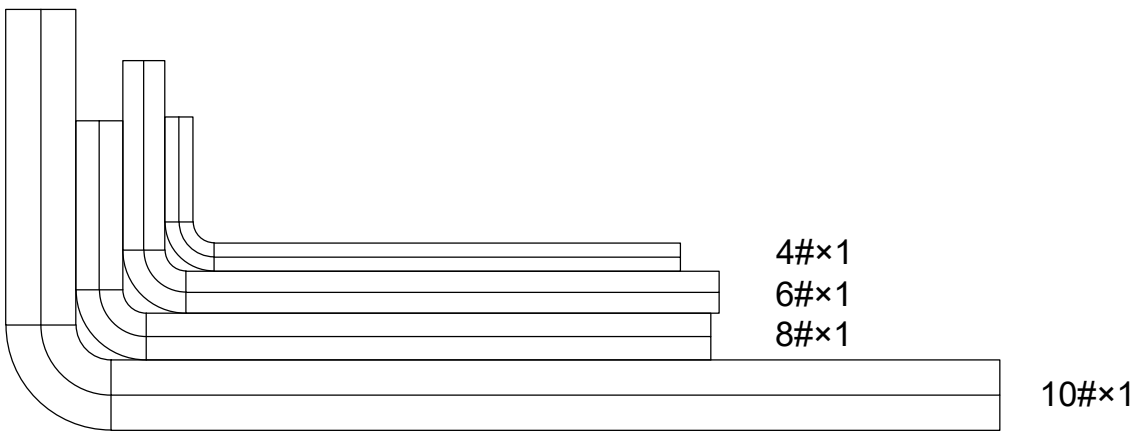
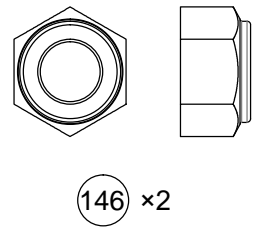
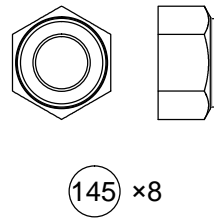
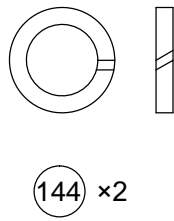
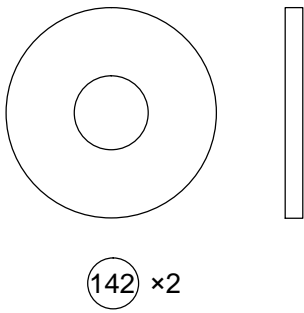
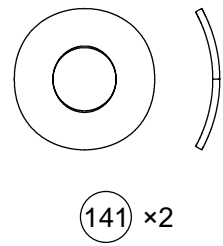
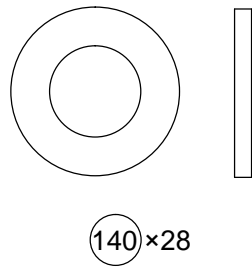
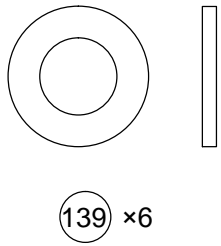
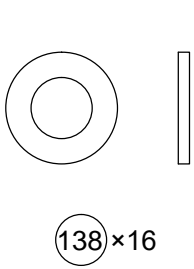

125



x28 M12x25mm

140



x28 φ24xφ13

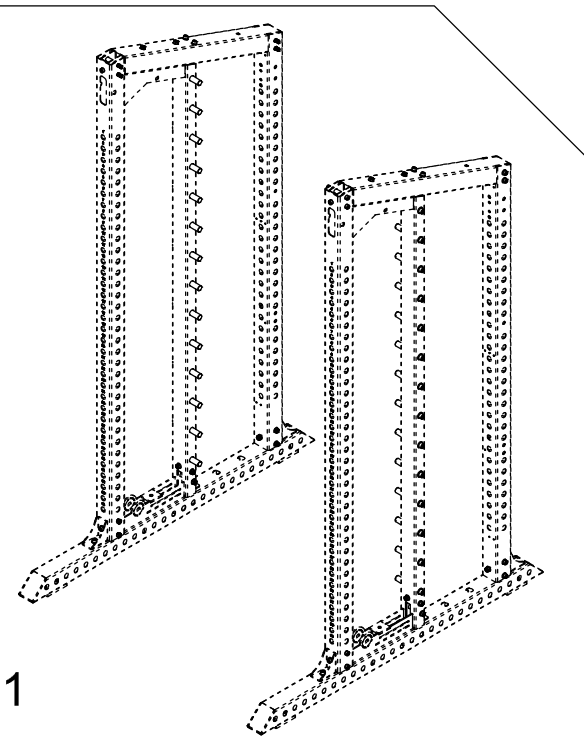
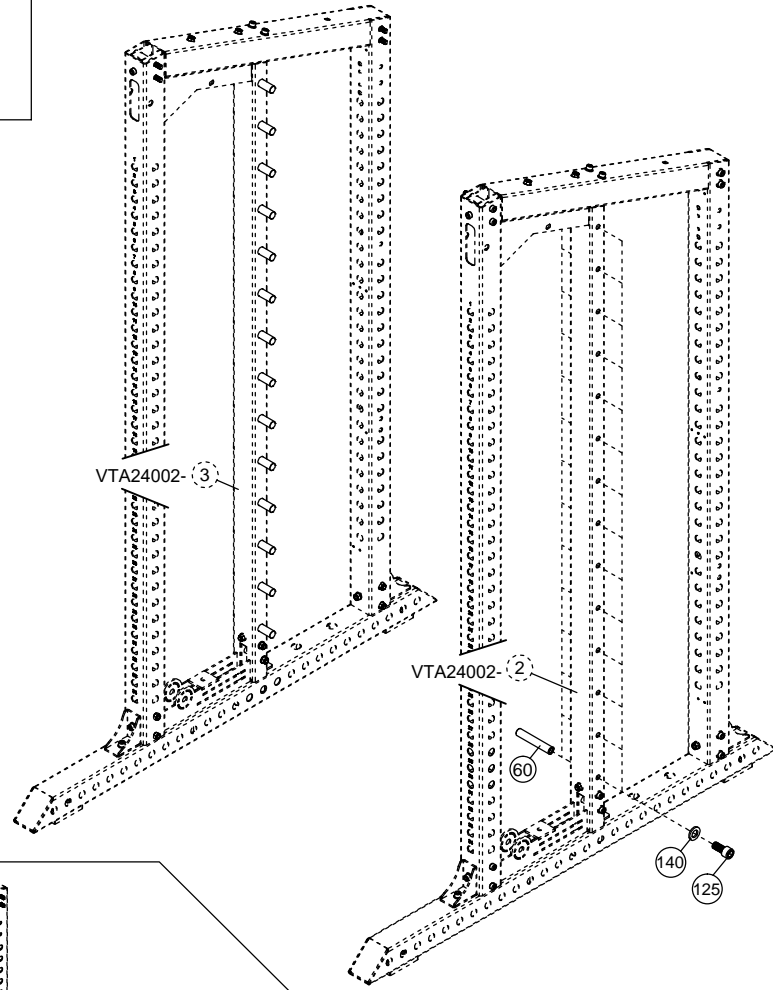
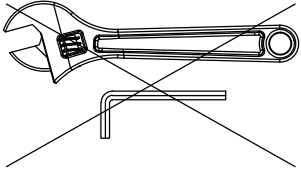

114  ×2 M10×75mm

139  ×6 φ20×φ10.5

120  ×2 M10×20mm



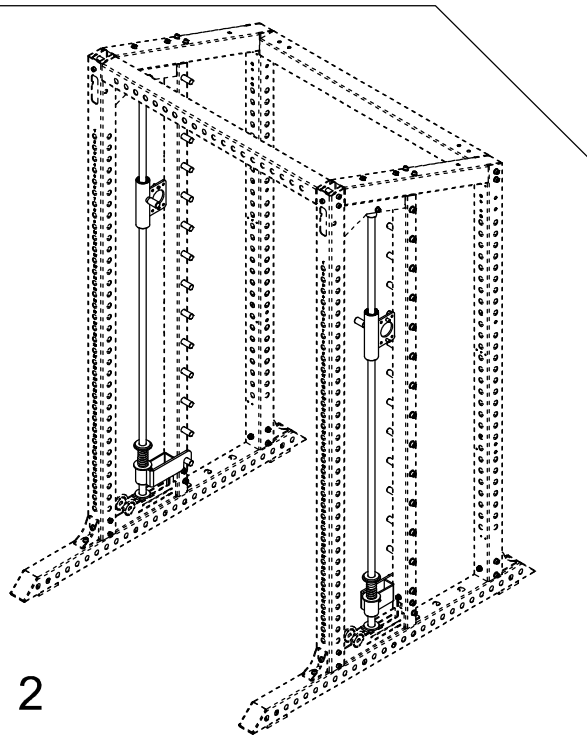
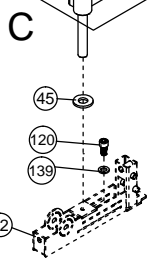
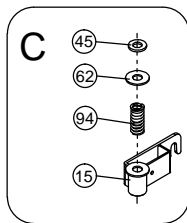
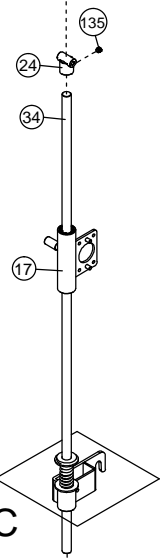
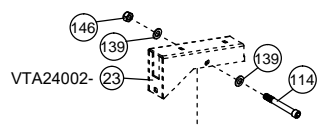
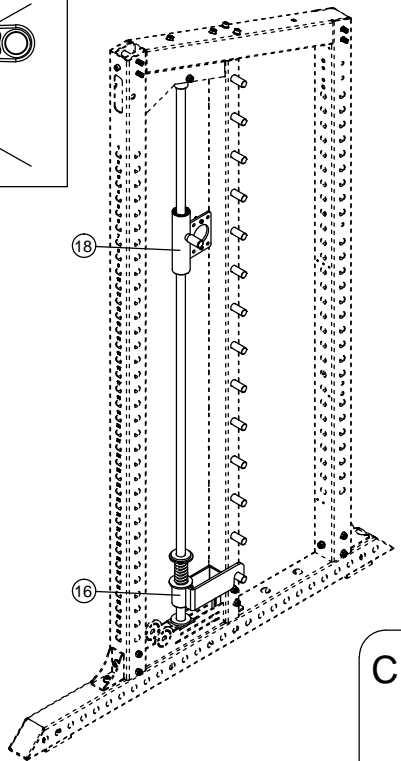
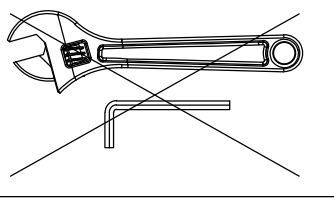

146  ×2 M10

135  ×2 M8×8mm



2

- ⑩107  ×2 M8×20mm
- ⑩108  ×8 M8×30mm
- ⑩119  ×2 M10×25mm
- ⑩128  ×2 M10×20mm

- ⑩138  | ×16 φ16×φ9
- ⑩141  ) ×2 20×R20×φ9
- ⑩142  | ×2 φ30×φ10.5
- ⑩144  | ×2 10
- ⑩145  | ×8 M8

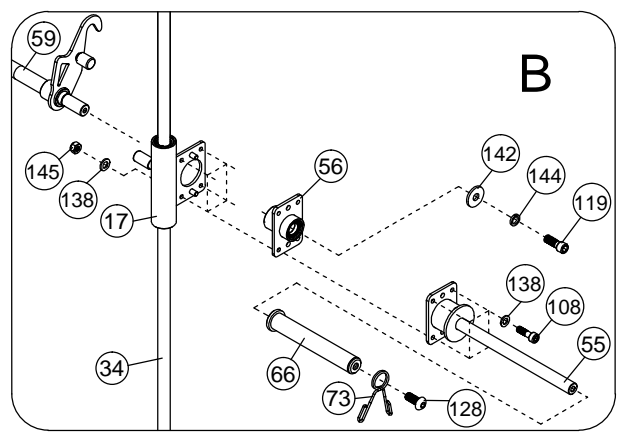
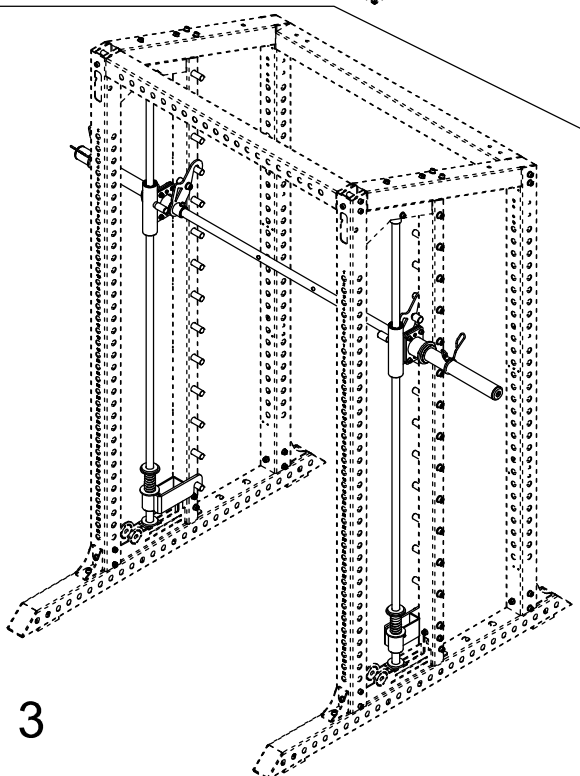
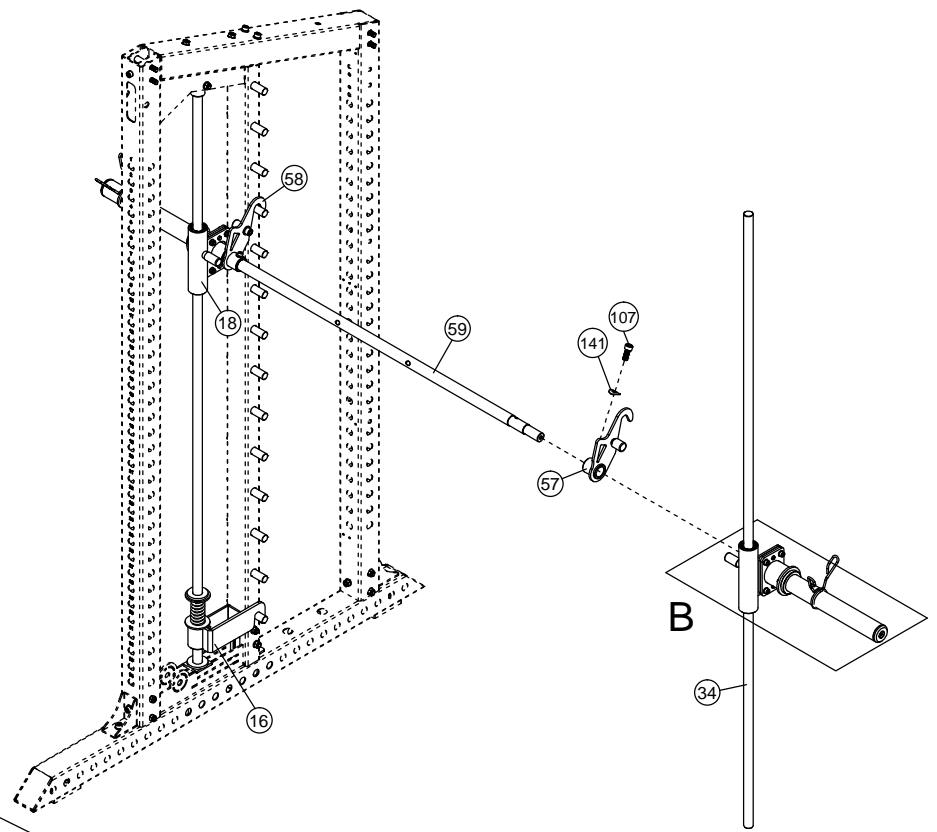
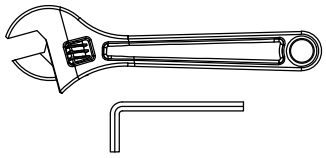

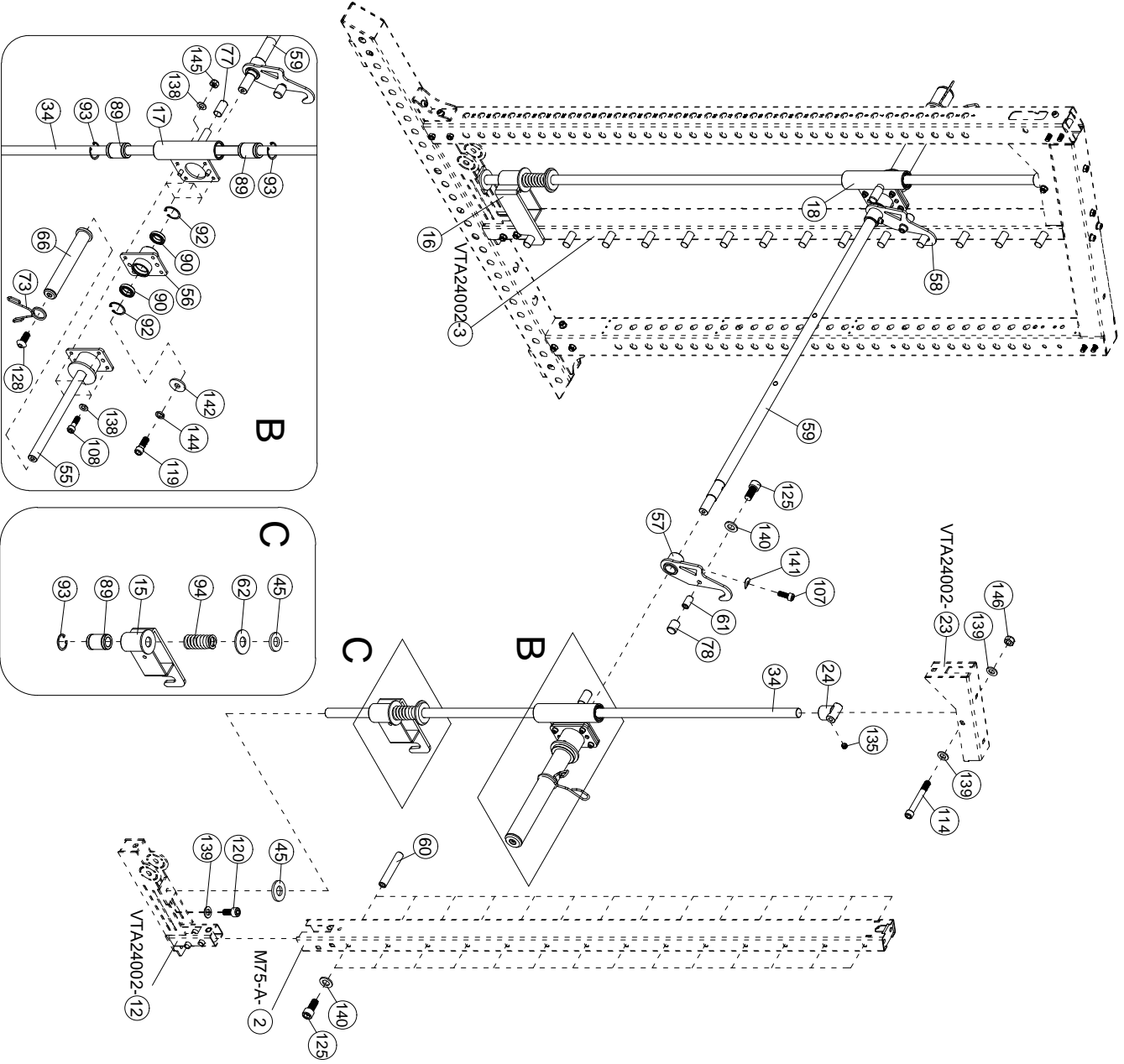

## VTA24003 PARTS LIST

KEY NO.	PART DESCRIPTION	SPEC	QTY
15	Safety Hook Bracket L		1
16	Safety Hook Bracket R		1
17	Mobile Rack L		1
18	Mobile Rack R		1
24	Upper Guide Rod Base		2
34	Guide Rod	φ25×1848×M10	2
45	Plastic Retaining Ring	φ50×φ26×6	4
55	Weights Stow Rod		2
56	Bearing Frame		2
57	Hanging Bar L		1
58	Hanging Bar R		1
59	Weight Rod	Φ30×1215×M10×M8	1
60	Hanging Post	φ20×115	28
61	Support Shaft	φ18×32×M12	2
62	Bracket	φ65×φ27×4	2
66	Long Olympic Sleeve		2
73	Spring Clip	φ47	2
77	Tube End Cap	φ19×42	2
78	Cushion Cover	φ18×φ25×30	2
89	Linear Motion Bearing	LB254058	6
90	Deep Groove Ball Bearing	61905	4
92	Hole Circlip	42	4
93	Hole Circlip	d0=40	6
94	Spring	φ43×φ27×φ8×80	2
107	Hexagon socket button head screws	M8×20	2
108	Hexagon socket button head screws	M8×30	8
114	Hexagon socket button head screws	M10×75	2
119	Hexagon socket button head screws	M10×25	2
120	Hexagon socket button head screws	M10×20	2
125	Hexagon socket button head screws	M12×25	30
128	Allen Bolt	M10×20	2
135	Set Screw	M8×8	2
138	Washer	8	16
139	Washer	10	6
140	Washer	12	30
141	Washer	20×R20×φ9	2
142	Washer	φ30×φ10.5×2.5	2
144	Washer	10	2

## PARTS LIST

KEY NO.	PART DESCRIPTION	SPEC	QTY
145	Nut	M8	8
146	Nut	M10	2
	Allen Wrench	4#	1
	Allen Wrench	6#	1
	Allen Wrench	8#	1
	Allen Wrench	10#	1

# VESTA

F I T N E S S

ASSEMBLY MANUAL

VTA24004

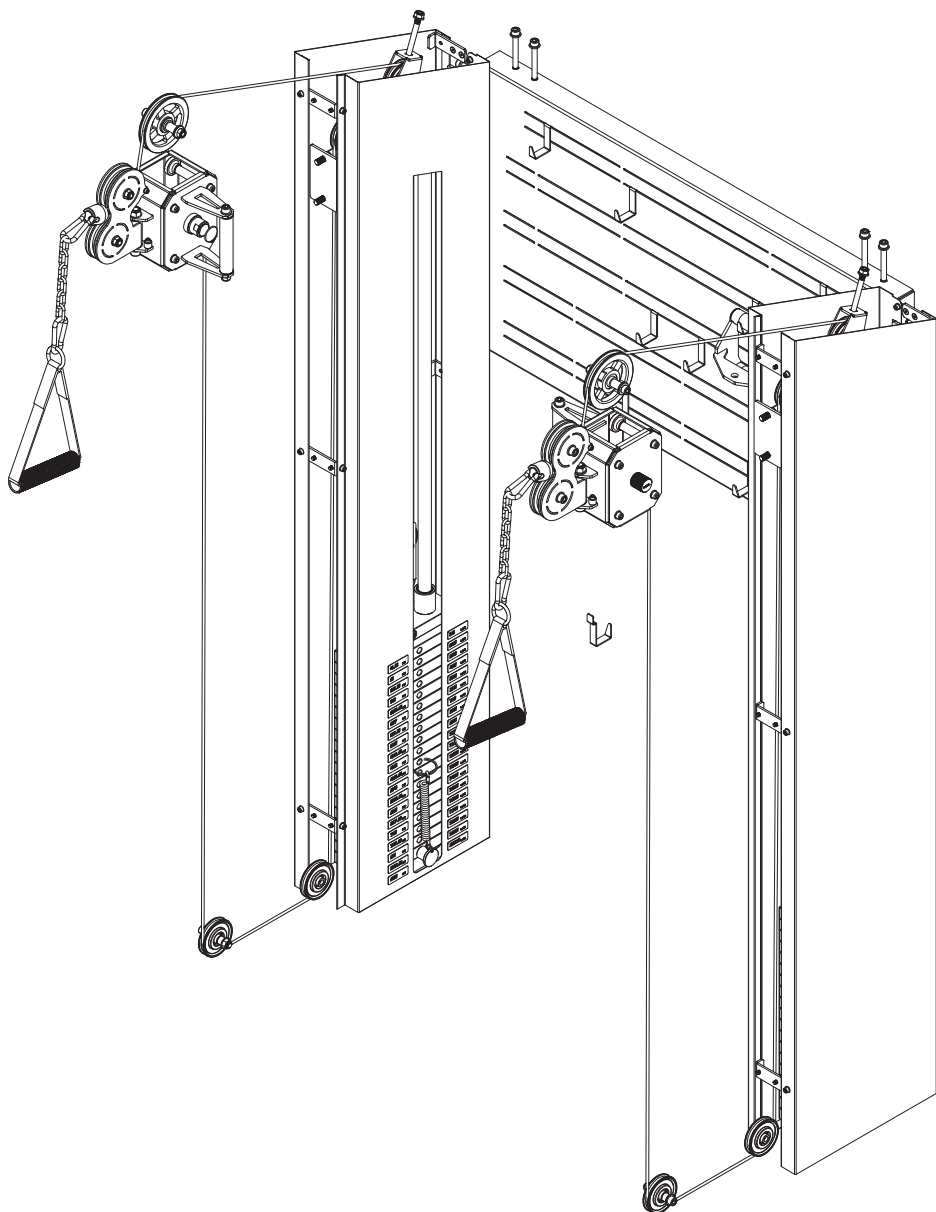

## CAUTION!

Read all precautions and instructions in this manual before using this equipment.

20241025-V1.0

## **IMPORTANT SAFETY NOTICE**

### **PRECAUTIONS**

This exercise machine is built for optimum safety. However, certain precautions apply whenever you operate a piece of exercise equipment. Be sure to read the entire manual before you assemble or operate your machine. In particular, note the following safety precautions:

1. **Keep children and pets away from the machine at all times. DO NOT leave children unattended in the same room with the machine.**
2. Only one person at a time should use the machine.
3. If the user experiences dizziness, nausea, chest pain, or any other abnormal symptoms, STOP the workout at once. CONSULT A PHYSICIAN IMMEDIATELY.
4. Position the machine on a clear, leveled surface. DO NOT use the machine near water or outdoors.
5. Keep hands away from all moving parts.
6. Always wear appropriate workout clothing when exercising. DO NOT wear robes or other clothing that could become caught in the machine. Running or aerobic shoes are also required when using the machine.
7. Use the machine only for its intended use as described in this manual. DO NOT use attachments not recommended by the manufacturer.
8. Do not place any sharp object around the machine.
9. Disabled person should not use the machine without a qualified person or physician in attendance.
10. Before using the machine to exercise, always do stretching exercises to properly warm up.
11. Never operate the machine if the machine is not functioning properly.

**WARNING: BEFORE BEGINNING ANY EXERCISE PROGRAM, CONSULT YOUR PHYSICIAN. THIS IS ESPECIALLY IMPORTANT FOR INDIVIDUALS OVER THE AGE OF 35 OR PERSONS WITH PRE-EXISTING HEALTH PROBLEMS. READ ALL INSTRUCTIONS BEFORE USING ANY FITNESS EQUIPMENT. WE ASSUME NO RESPONSIBILITY FOR PERSONAL INJURY OR PROPERTY DAMAGE SUSTAINED BY OR THROUGH THE USE OF THIS PRODUCT.**

**SAVE THESE INSTRUCTIONS.**

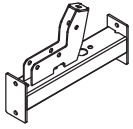

11x2



19x2



25x2

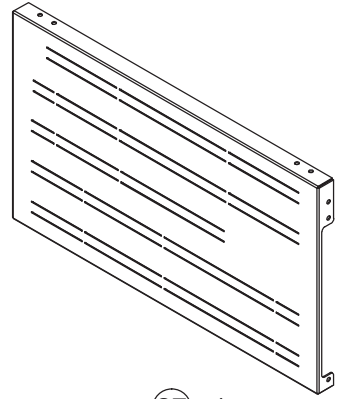

27x1

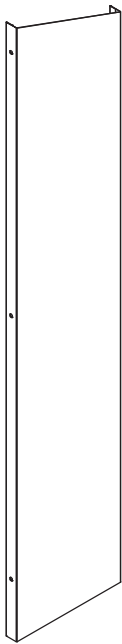

28x1

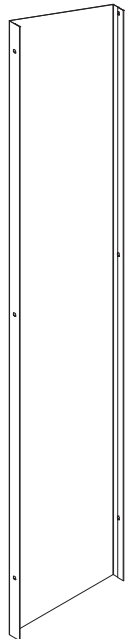

29x1

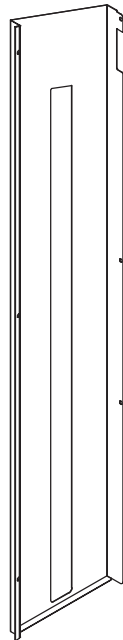

30x1

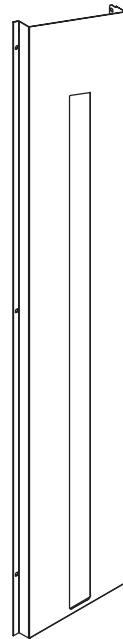

31x1



35x4



32x6



33x6



36x2



40x12



41x4



49x2



53x2



64x4



72x1



74x4



75x2



76x1



82x2



85x4



86 x 2



87 x 4



88 x 12



91 x 2

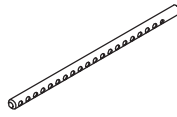

95 x 2



96 x 2

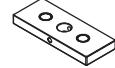

97 x 38

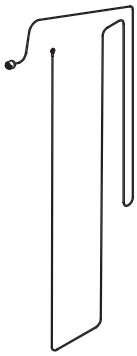

48 x 2

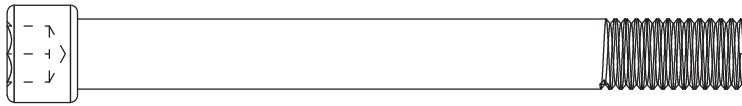

(111) × 10

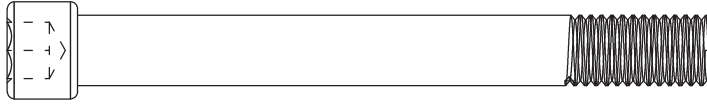

(112) × 2

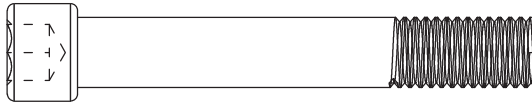

(115) × 4

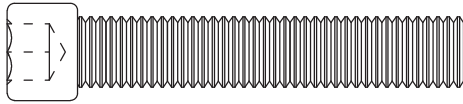

(116) × 2

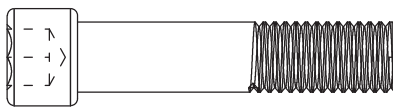

(117) × 12

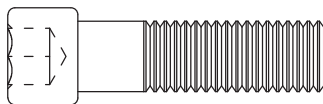

(118) × 2

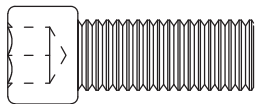

(119) × 6

mm

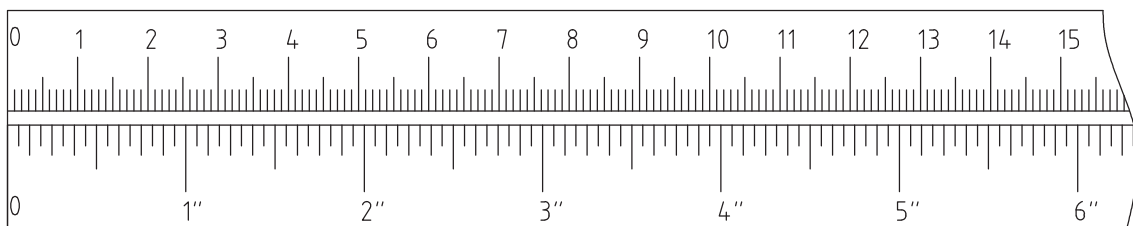

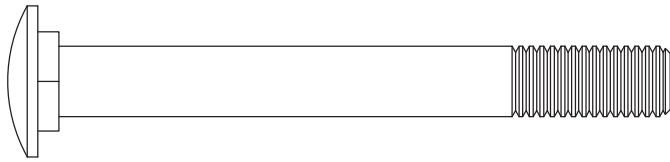

(121) × 2

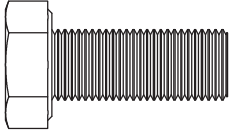

(123) × 2

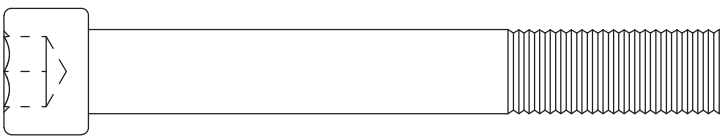

(126) × 2



(130) × 24

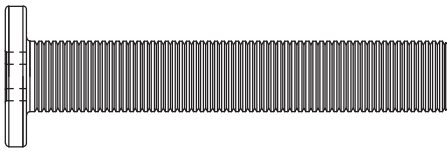

(131) × 2

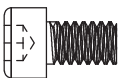

(105) × 24

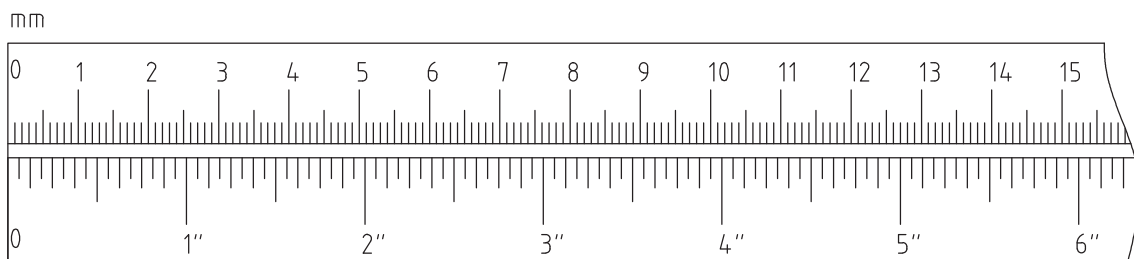

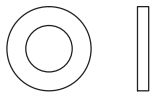

①37×24

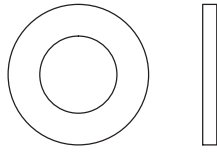

①39×60

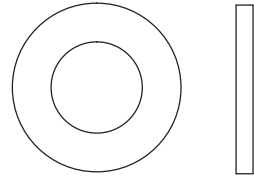

①40×4

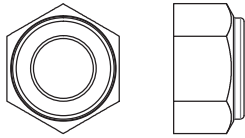

①46×30

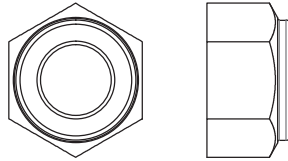

①47×2

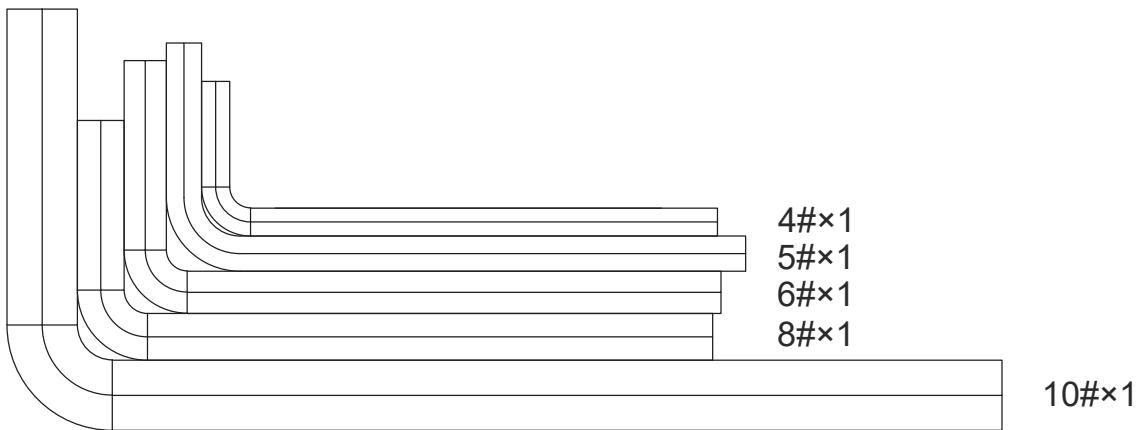

mm

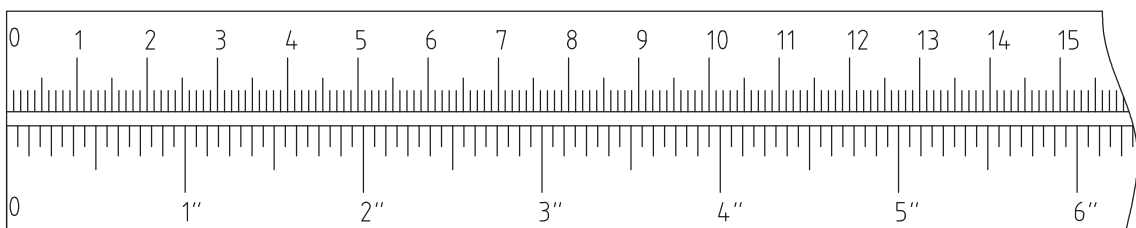

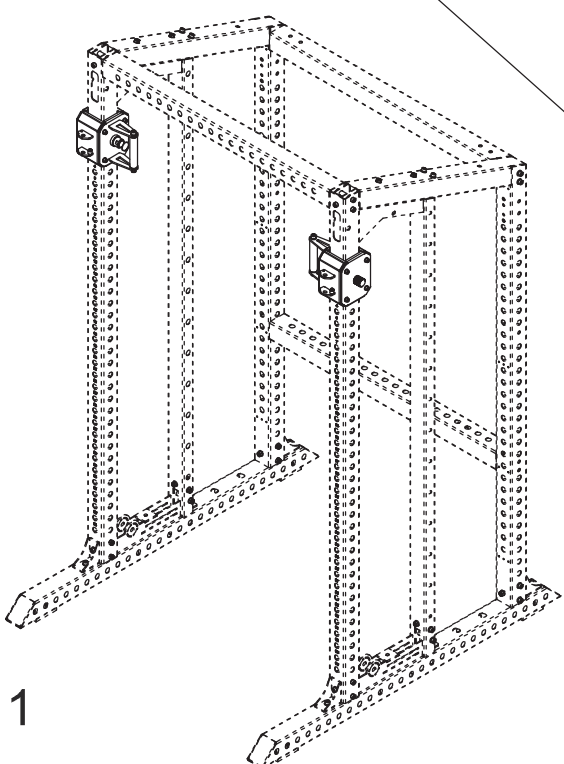
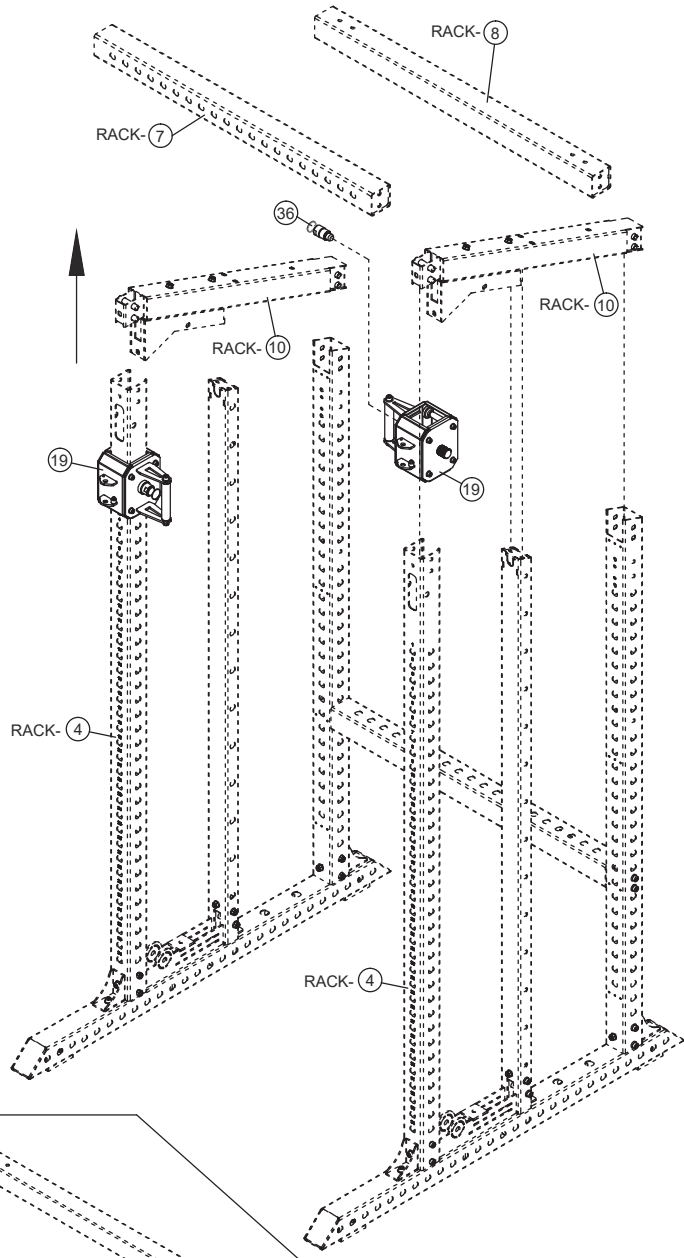
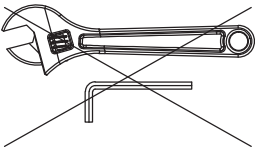

111

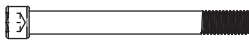

×10

M10×95mm

139



×20

φ20×φ10.5

146



×10

M10

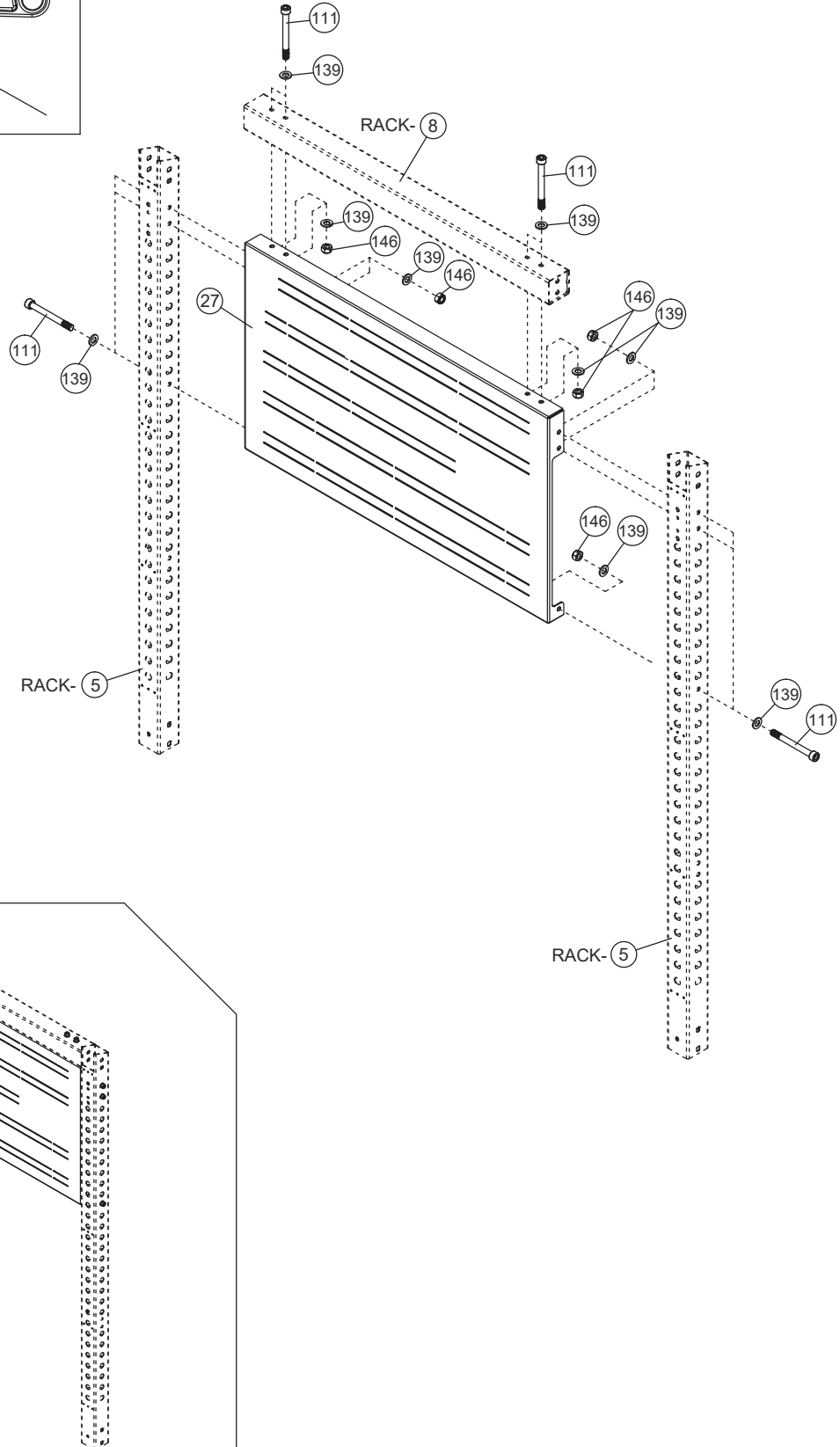
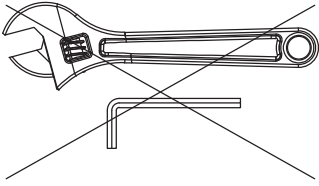

2

130



× 24 M6×10mm

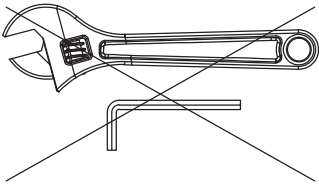

VTA24002- (3)



RACK- (5)



VTA24002- (2)





(33) (130)

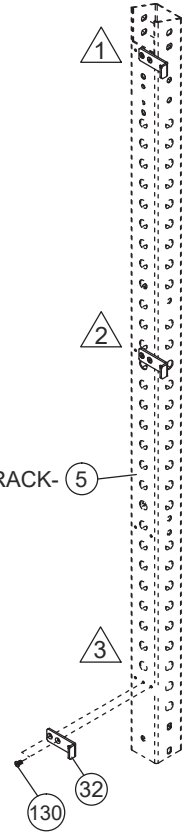

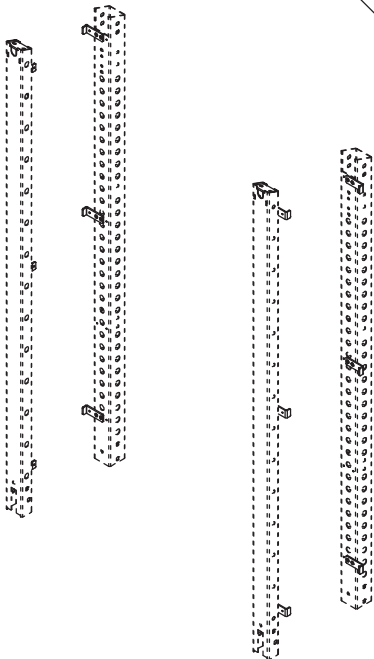

RACK- (5)

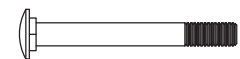

3



- ①115  ×2 M10×65mm
- ①116  ×2 M10×55mm
- ①119  ×6 M10×25mm
- ①121  ×2 M10×90mm

- ①139  ×12 φ20×φ10.5
- ①146  ×2 M10
- ①131  ×2 M10×60mm
- ①123  ×2 M10×25mm

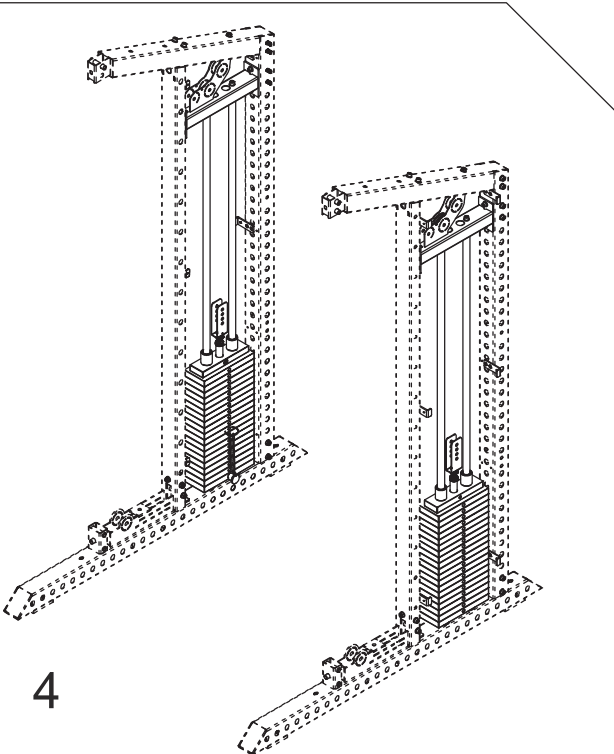
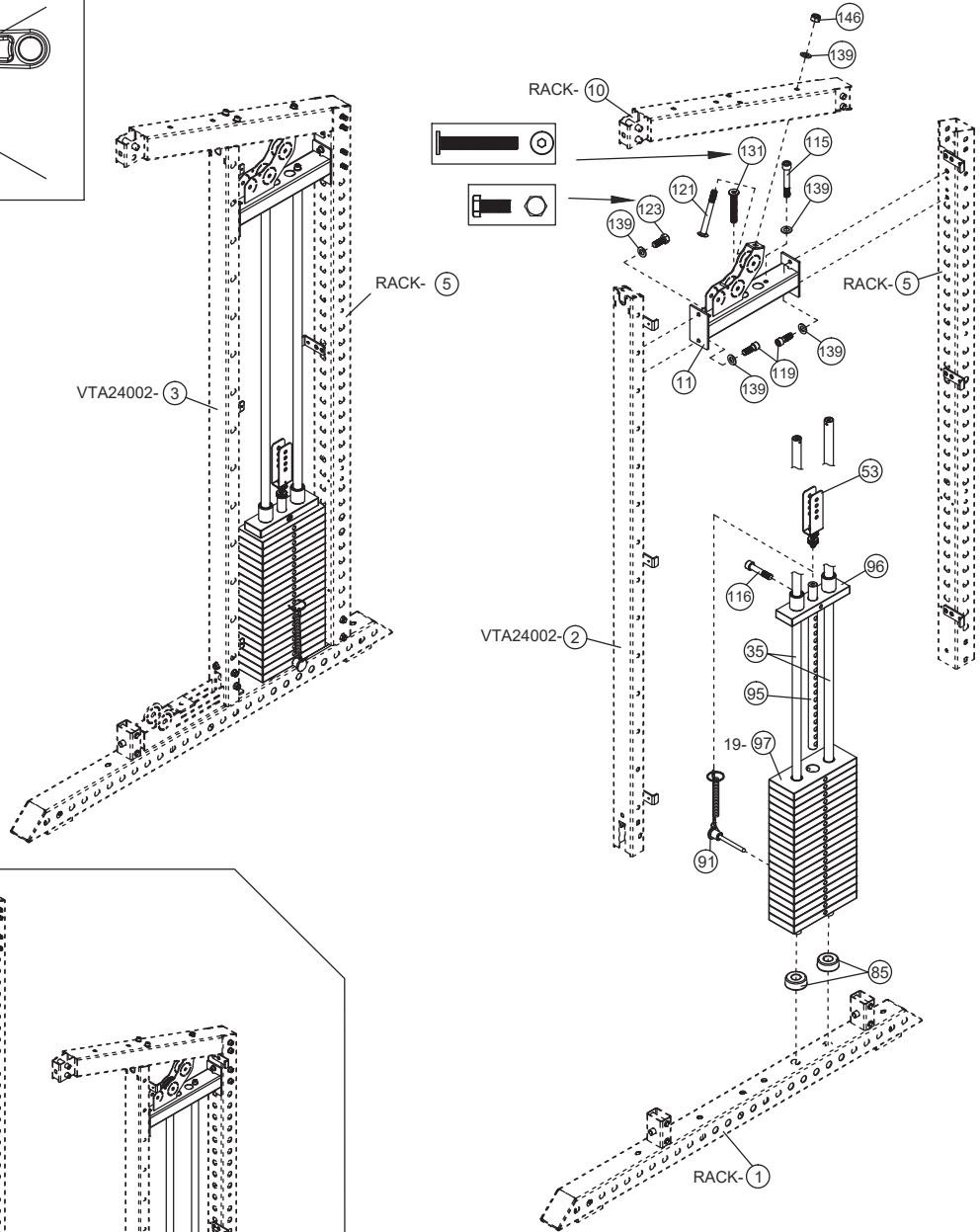
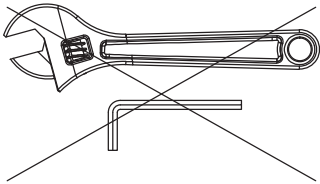

112		×2	M10×90mm	139		×28	φ20×φ10.5
115		×2	M10×65mm	140		×4	φ24×φ13
117		×12	M10×45mm	146		×18	M10
118		×2	M10×35mm	147		×2	M12
126		×2	M12×90mm				

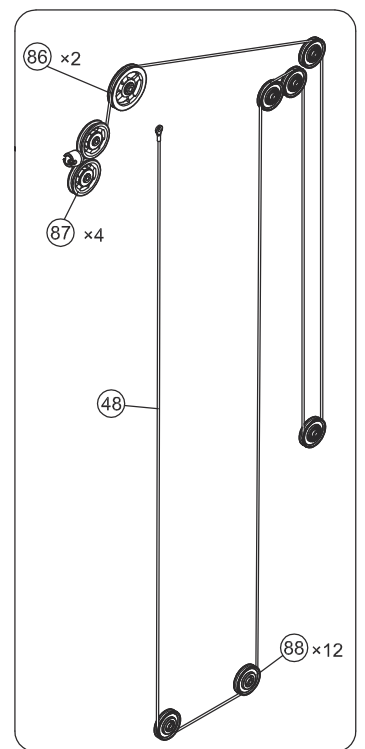
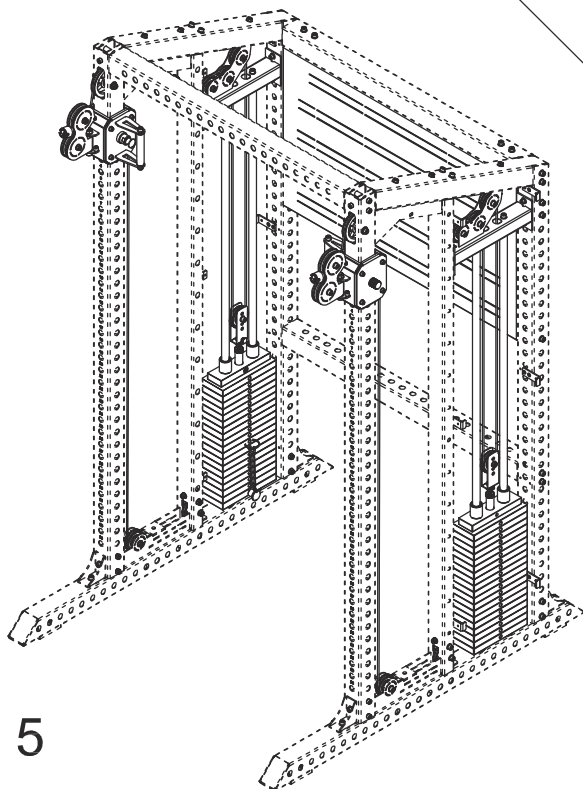
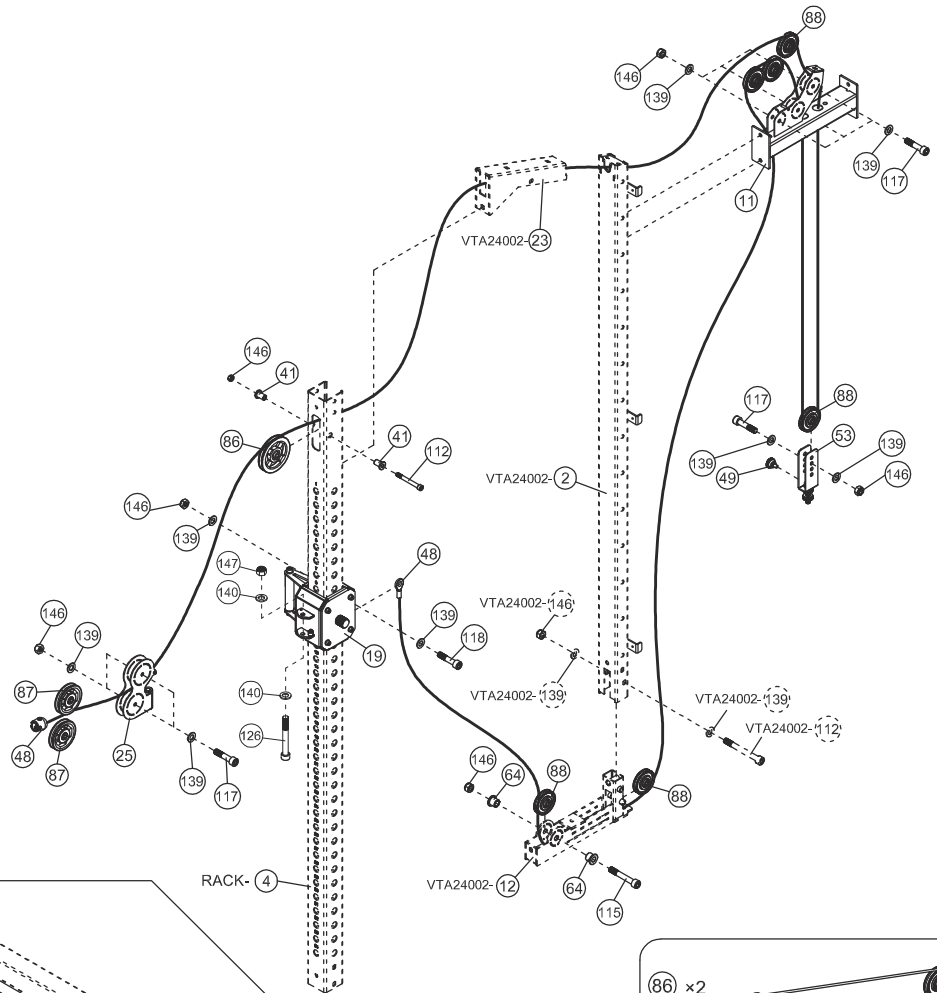
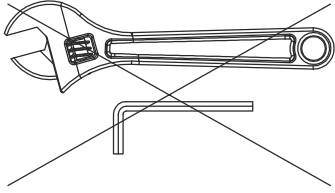

105



× 24 M6×10mm

137



× 24 φ12×φ6.6

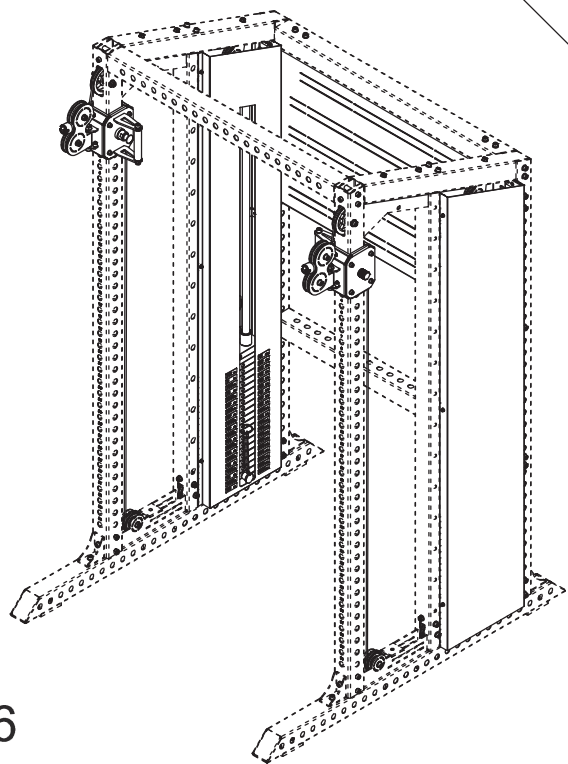
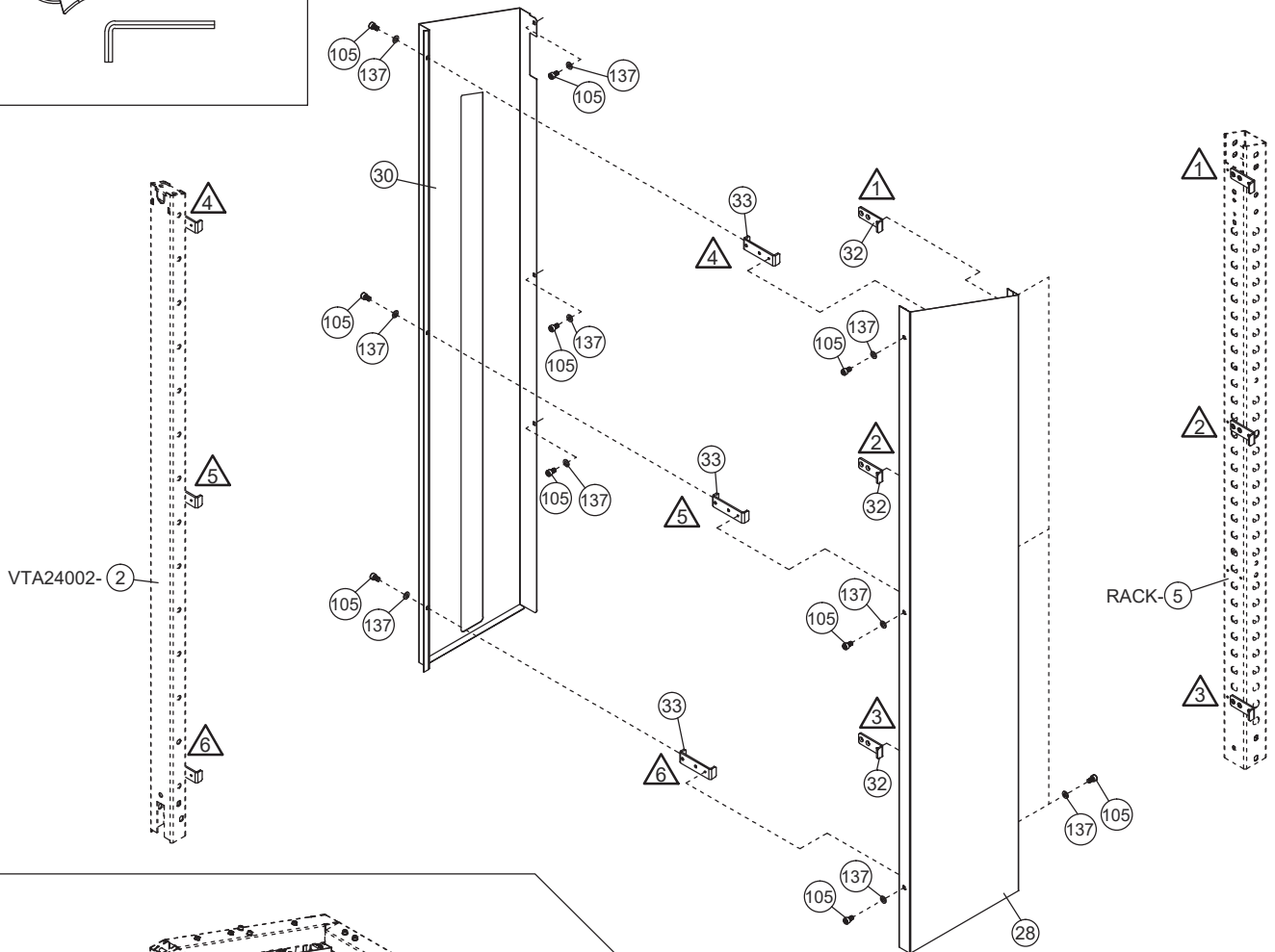
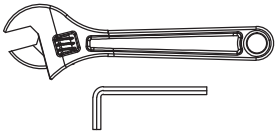

6

Assemble the inner cover (30) first, then assemble the outer cover (28).

Installation order is the same for left and right side.

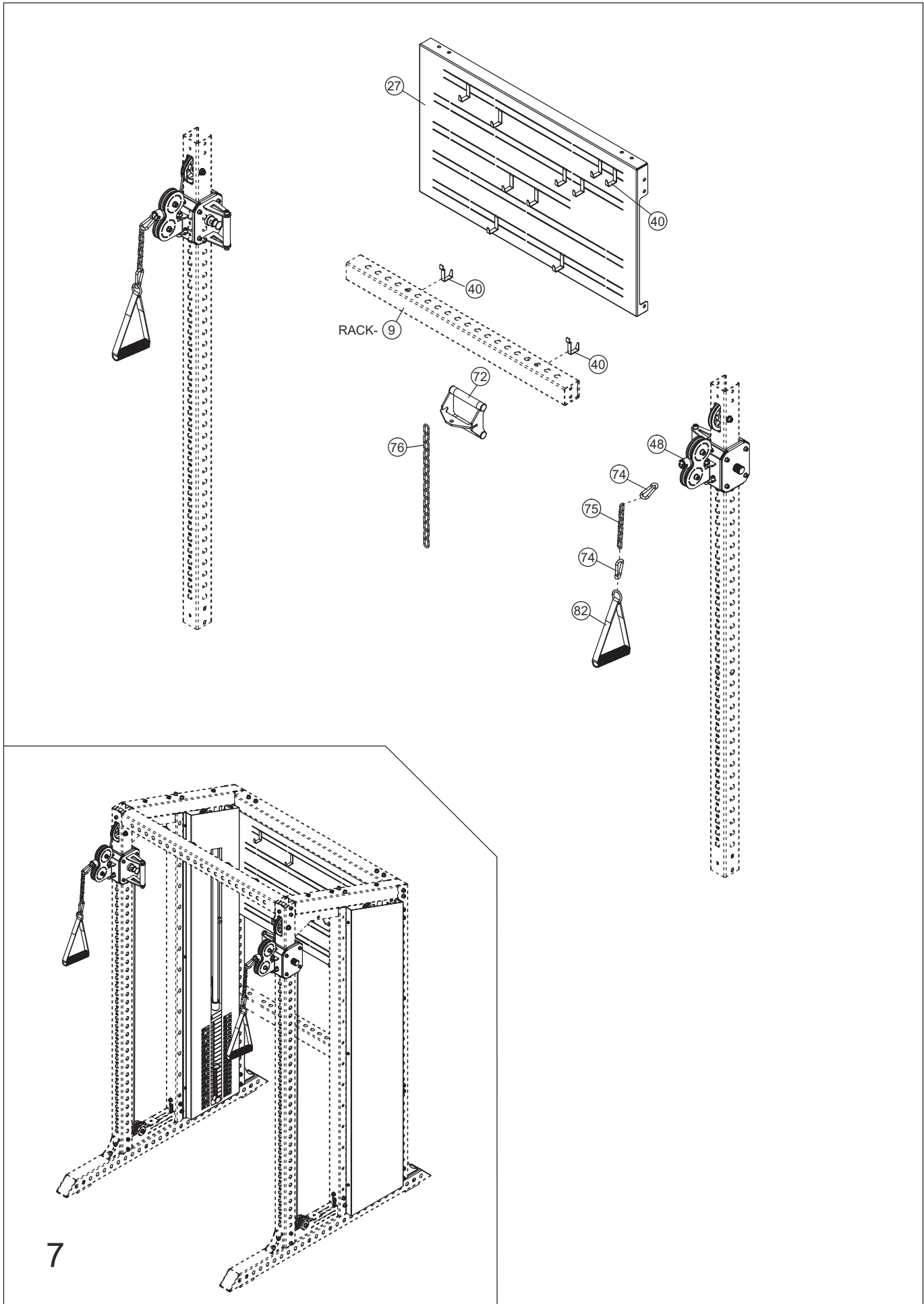

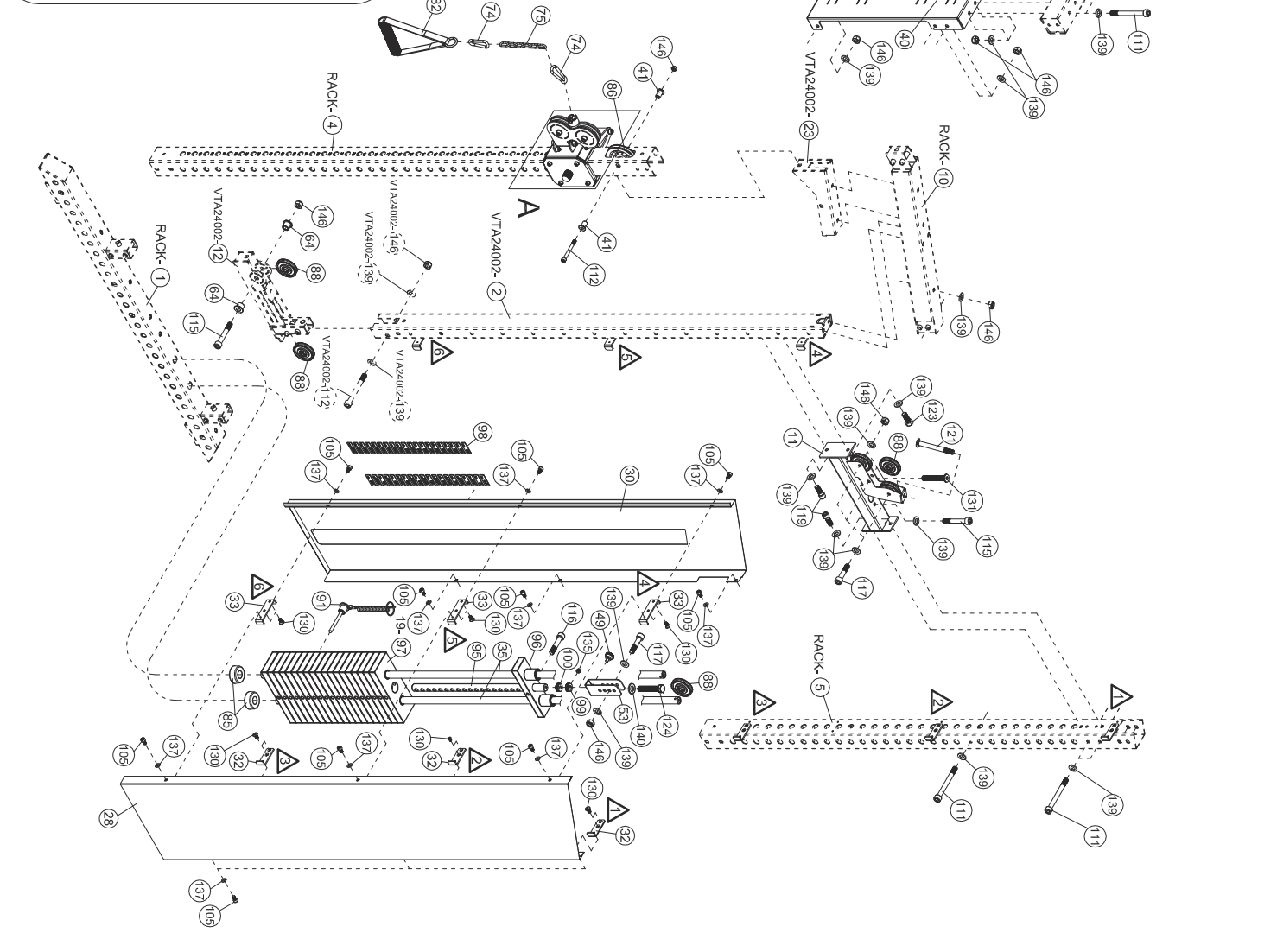
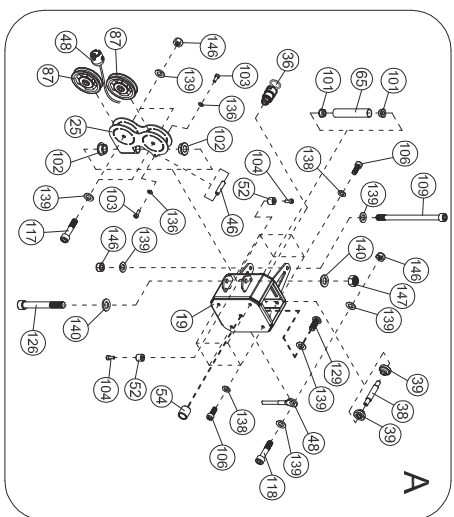
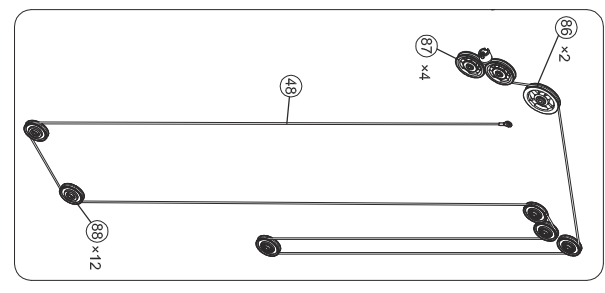

# VTA24004 PARTS LIST

KEY NO.	PART DESCRIPTION	SPEC	QTY
11	Connecting Frame On Guide Rod		2
19	Roller Sliding Frame		2
25	Pulley Case		2
27	Rear Panel	1095×643×55×3	1
28	Left Outer Shield	1900×368.6×1	1
29	Right Outer Shield	1900×368.6×1	1
30	Left Inner Shield	1899×366.6×1	1
31	Right Inner Shield	1899×366.6×1	1
32	Shield Fixing L Plate	81×20×30×4	6
33	Shield Fixing Plate	107×20×20×30×4	6
35	Guide Rod Rear		4
36	Lock Pin		2
38	Roller Shaft	φ16×φ12×95×M8	8
39	Contact Roller	φ35×φ12.1×19.7	16
40	Hook		12
41	Bushing	φ25×φ16×φ10.2×27	4
46	Retaining Column	φ8×25×M5	2
48	Double pull cable	<b>L=7050</b>	2
49	Knurled Thumb Screws	M6×10	2
52	Bushing	φ14×φ6×12	4
53	Pulley Case	135×50×3×M6	2
54	Aluminum alloy Bolt Head	φ28×φ25×30×M10	2
64	Bushing	φ22×φ10.2×15	4
65	Handle tube	φ25×2×125	2
72	V-type handle		1
74	Hook	φ8	4
75	6-Joint Chain		2
76	15-Joint Chain		1
79	End Cap	φ28	4
82	Nylon Strap Iso-Handle	L=245mm	2
85	Rubber Stopper	φ62×φ24.5×25	4
86	Pulley with Bearings	φ114×φ10	2
87	Pulley with Bearings	φ95×φ10	4
88	Pulley with Bearings	φ72×φ10	12
91	Weight Selector Pin		2
95	Selector Rod	φ25×564 (19+1)	2
96	Top Weight Plate	230×65×72	2
97	Weight Plate	250×100×25.4 (10LB)	38

## PARTS LIST

KEY NO.	PART DESCRIPTION	SPEC	QTY
98	Weight Plate Sticker (200LBS)	52×18	2
99	Knurled Nut	φ28×12×M12	2
100	Adjusting Sleeve	φ28×φ12.5×12	2
101	Bushing	φ25×φ21.8×φ10.5×12	4
102	Bushing	φ25×φ20×φ12.2×10	4
103	Hexagon socket button head screws	M5×10	4
104	Hexagon socket button head screws	M5×16	4
105	Hexagon socket button head screws	M6×10	24
106	Hexagon socket button head screws	M8×16	16
109	Hexagon socket button head screws	M10×155	2
111	Hexagon socket button head screws	M10×95	10
112	Hexagon socket button head screws	M10×90	2
115	Hexagon socket button head screws	M10×65	4
116	Hexagon socket button head screws	M10×55	2
117	Hexagon socket button head screws	M10×45	12
118	Hexagon socket button head screws	M10×35	2
119	Hexagon socket button head screws	M10×25	6
121	Carriage Bolt	M10×90	2
123	Hex Bolt	M10×25	2
124	Hex Bolt	M12×60	2
126	Hexagon socket button head screws	M12×90	2
129	Allen Bolt	M10×25	2
130	Hexagon socket countersunk head screws	M6×10	24
131	Allen Bolt	M10×60	2
135	Set Screw	M8×8	2
136	Washer	5	4
137	Washer	6	24
138	Washer	8	16
139	Washer	10	66
140	Washer	12	6
146	Nut	M10	32
147	Nut	M12	2
	Allen Wrench	4#	1
	Allen Wrench	5#	1
	Allen Wrench	6#	1
	Allen Wrench	8#	1
	Allen Wrench	10#	1