

VESTA

F I T N E S S

ASSEMBLY MANUAL

VTA24007

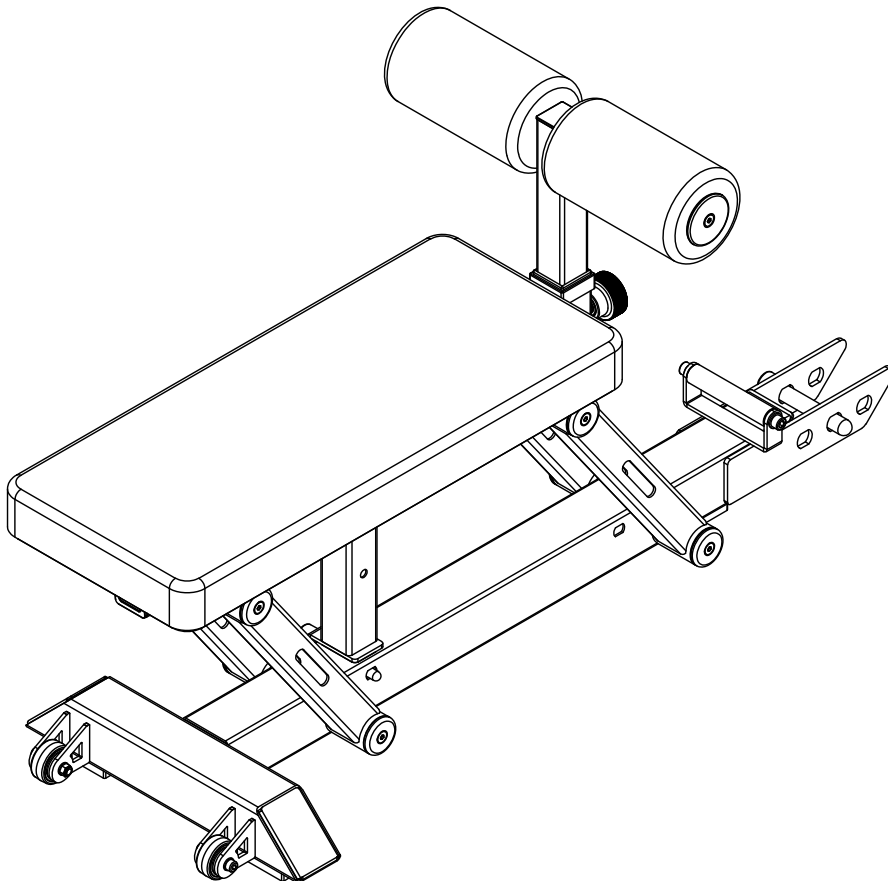

CAUTION!

Read all precautions and instructions in this manual before using this equipment.

20240802V1.0

IMPORTANT SAFETY NOTICE

PRECAUTIONS

This exercise machine is built for optimum safety. However, certain precautions apply whenever you operate a piece of exercise equipment. Be sure to read the entire manual before you assemble or operate your machine. In particular, note the following safety precautions:

1. **Keep children and pets away from the machine at all times. DO NOT leave children unattended in the same room with the machine.**
2. Only one person at a time should use the machine.
3. If the user experiences dizziness, nausea, chest pain, or any other abnormal symptoms, STOP the workout at once. CONSULT A PHYSICIAN IMMEDIATELY.
4. Position the machine on a clear, leveled surface. DO NOT use the machine near water or outdoors.
5. Keep hands away from all moving parts.
6. Always wear appropriate workout clothing when exercising. DO NOT wear robes or other clothing that could become caught in the machine. Running or aerobic shoes are also required when using the machine.
7. Use the machine only for its intended use as described in this manual. DO NOT use attachments not recommended by the manufacturer.
8. Do not place any sharp object around the machine.
9. Disabled person should not use the machine without a qualified person or physician in attendance.
10. Before using the machine to exercise, always do stretching exercises to properly warm up.
11. Never operate the machine if the machine is not functioning properly.
12. A spotter is recommended during exercise.

WARNING: BEFORE BEGINNING ANY EXERCISE PROGRAM, CONSULT YOUR PHYSICIAN. THIS IS ESPECIALLY IMPORTANT FOR INDIVIDUALS OVER THE AGE OF 35 OR PERSONS WITH PRE-EXISTING HEALTH PROBLEMS. READ ALL INSTRUCTIONS BEFORE USING ANY FITNESS EQUIPMENT. WE ASSUME NO RESPONSIBILITY FOR PERSONAL INJURY OR PROPERTY DAMAGE SUSTAINED BY OR THROUGH THE USE OF THIS PRODUCT.

SAVE THESE INSTRUCTIONS.

Assembled Dimension: 1307mm x 495mm x 671mm

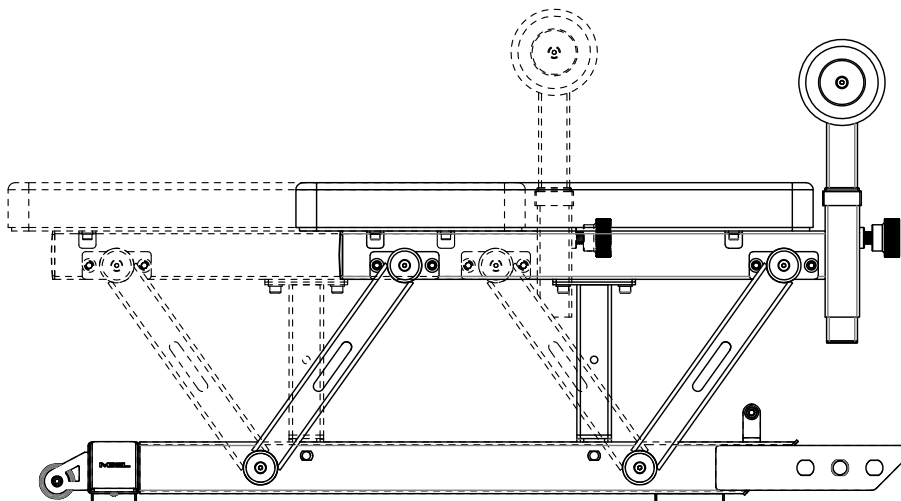
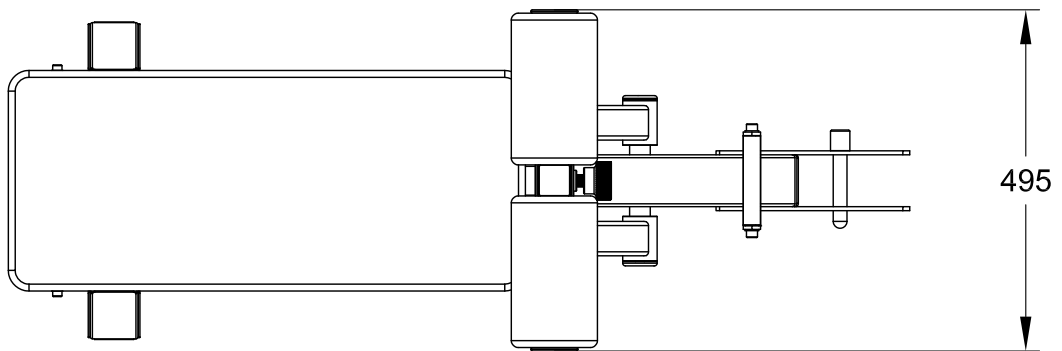
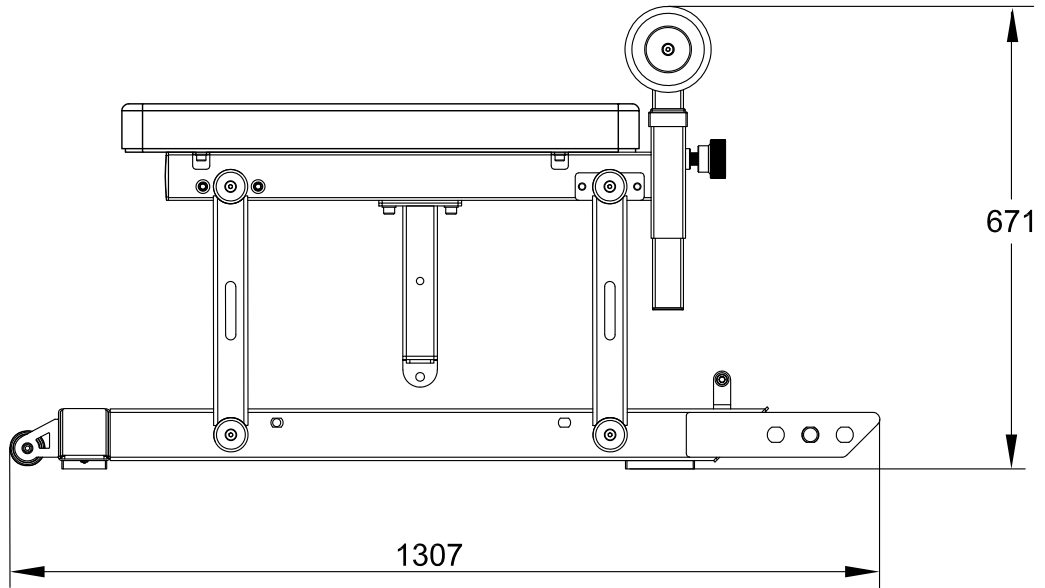

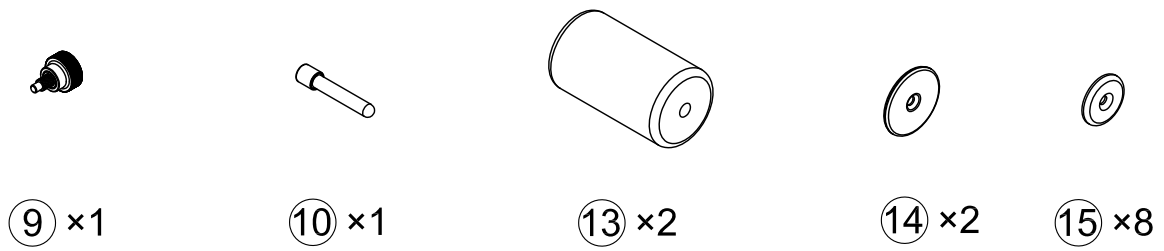
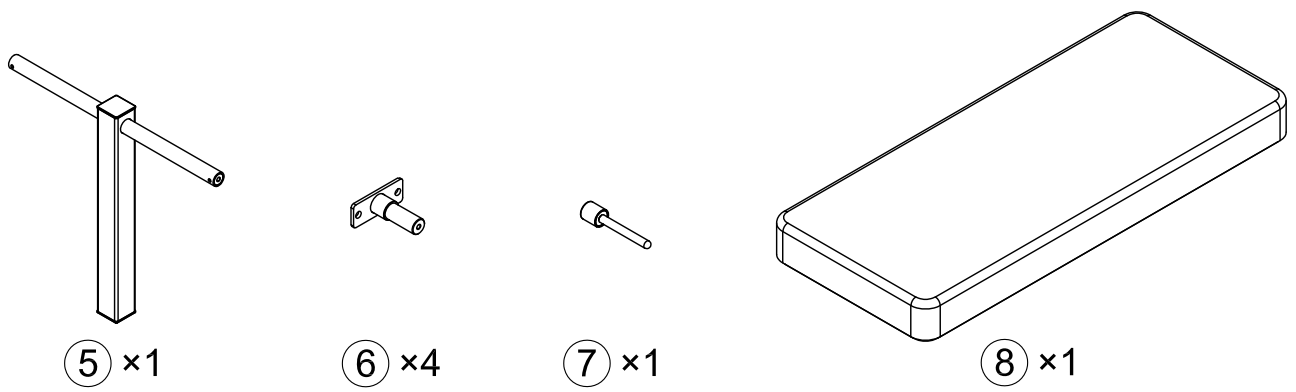
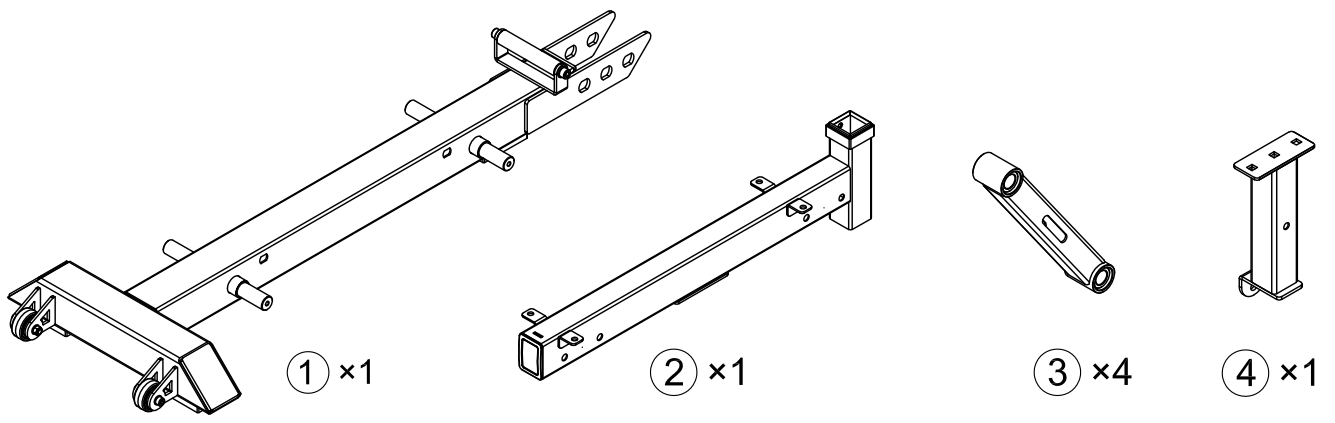

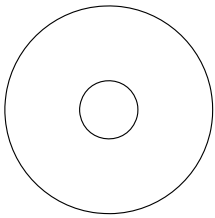

⑬ × 8



⑳ × 10

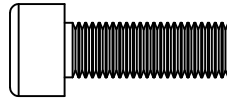

㉑ × 4

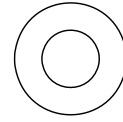

㉓ × 4

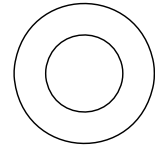

㉔ × 10

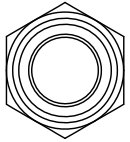

㉖ × 4



㉗ × 8

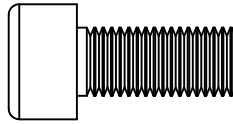

㉘ × 2

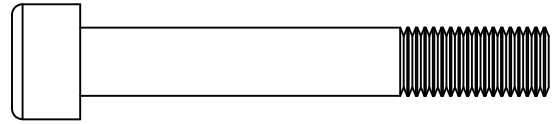

㉚ × 4

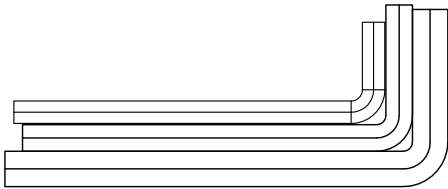

5# 6# 8# × 1

mm

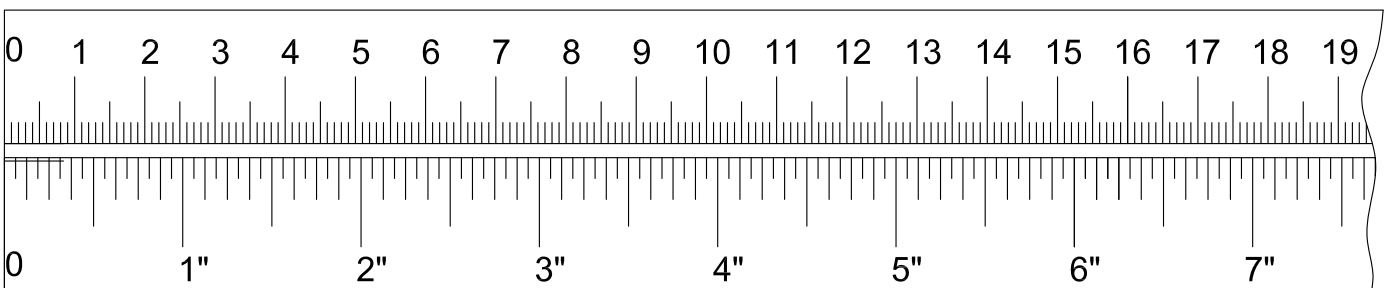

38  ×4 M10×75mm

33   ×4 M10

31   ×8 Φ10

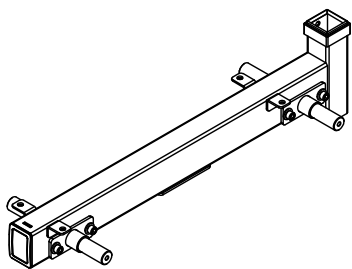
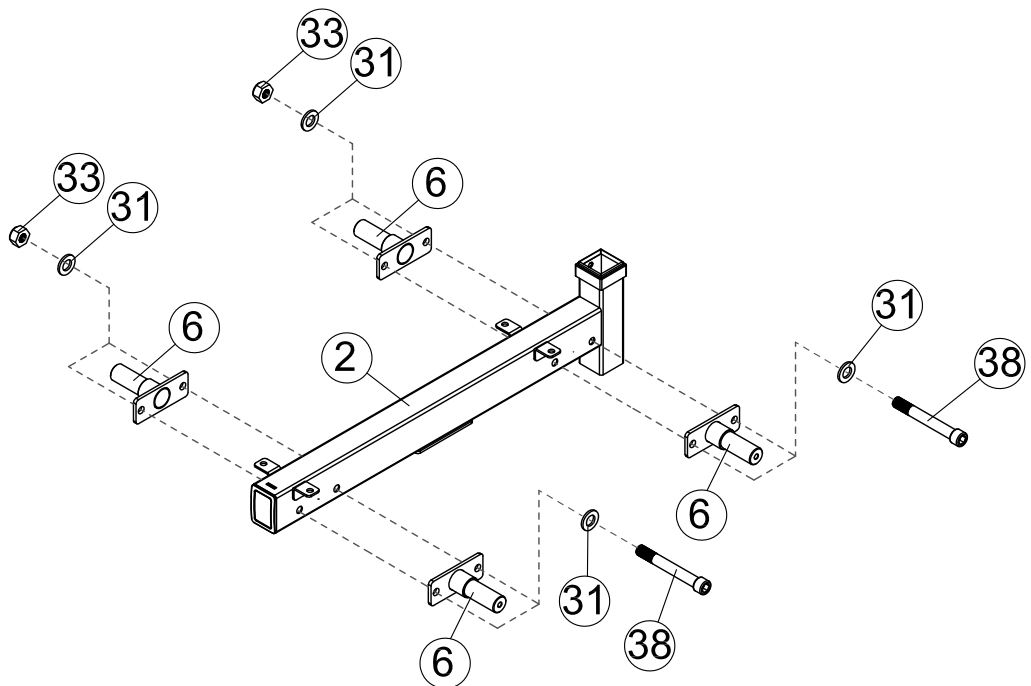
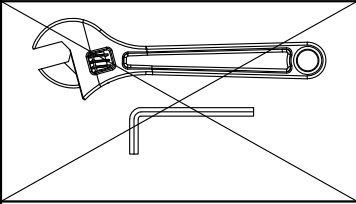

36



×2 M10×25mm

31



×2 Φ10

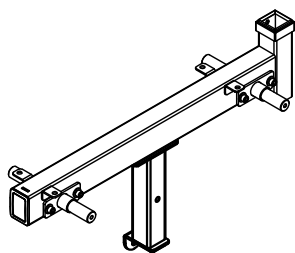
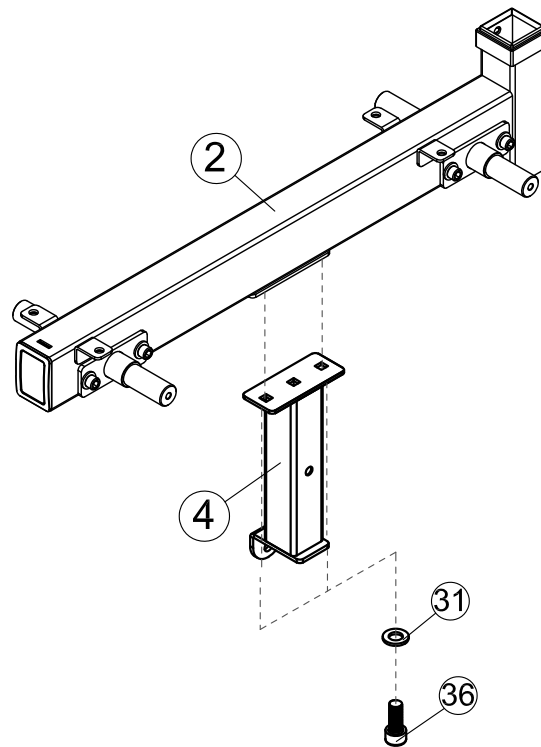
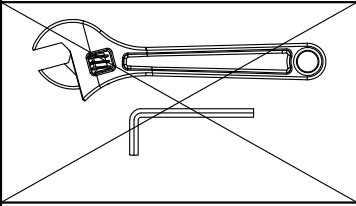

①⑥ ○ ×8 φ32×φ9

②⑤ ─ ×8 M8×30mm

③④ ○ ×8 φ8

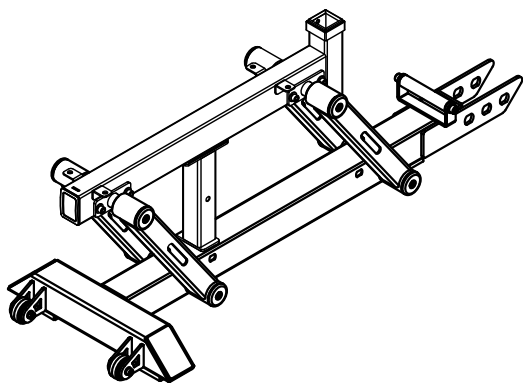
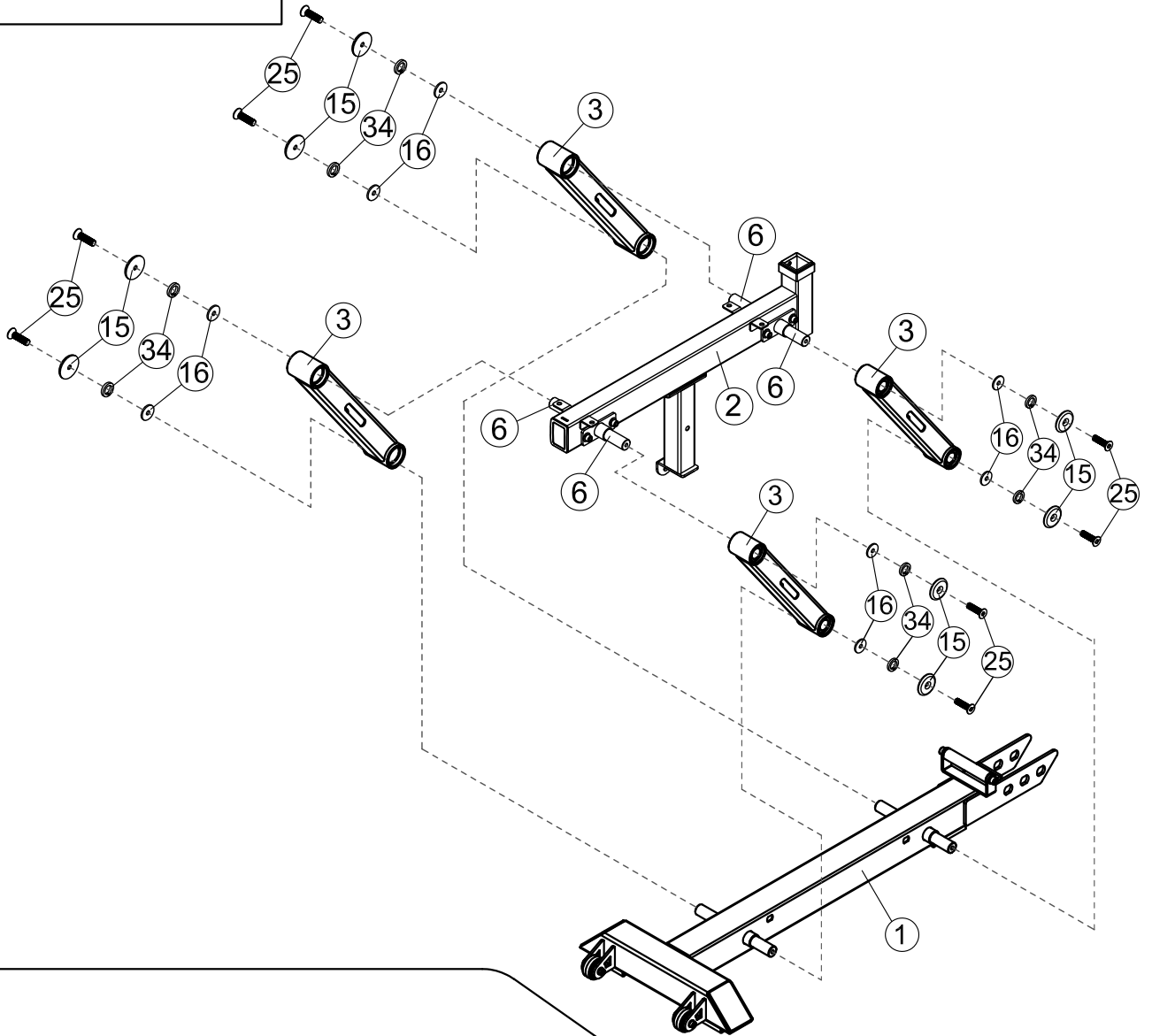
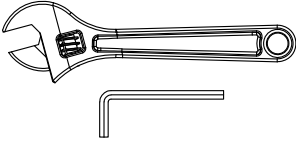

25



×2 M8×30mm

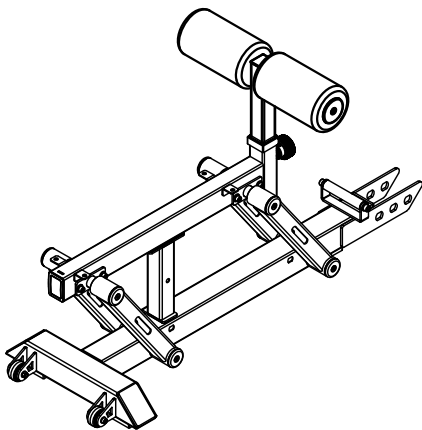
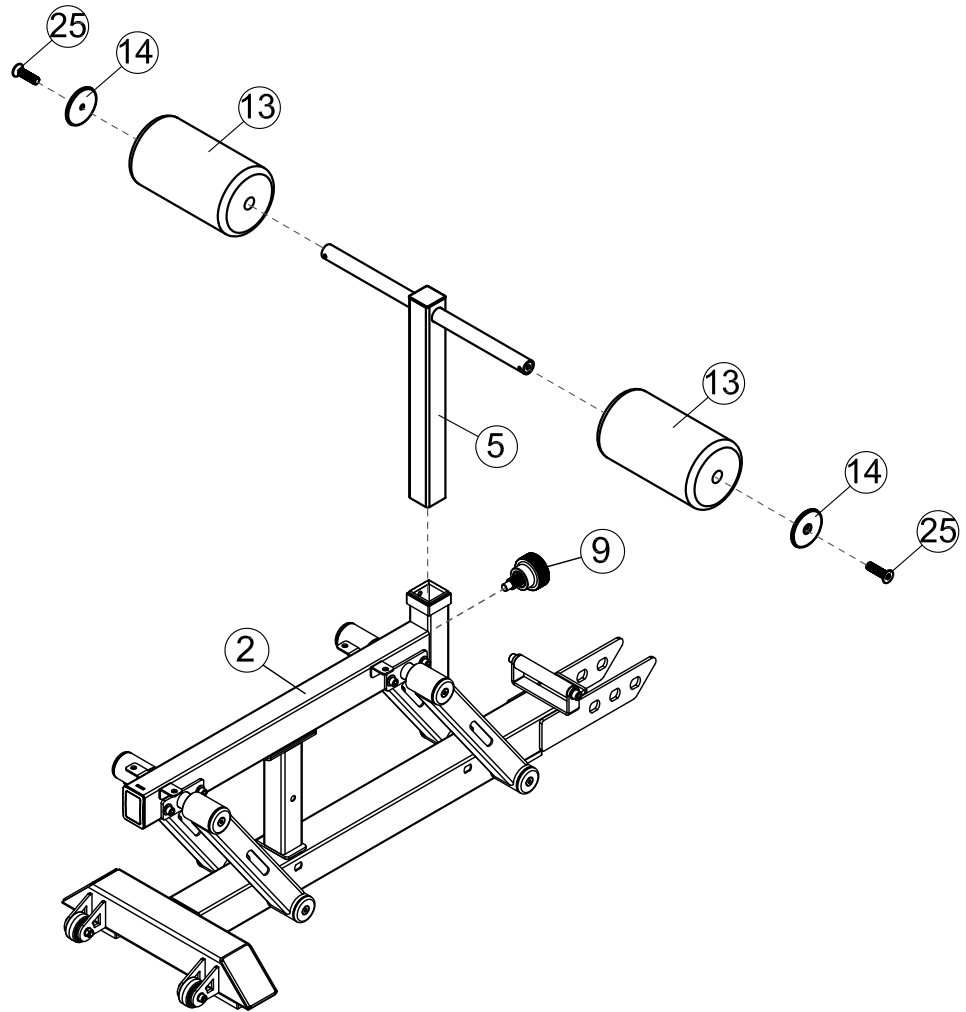
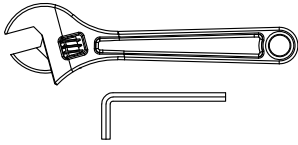

26



×4 M8×25mm

30



×4 Φ8

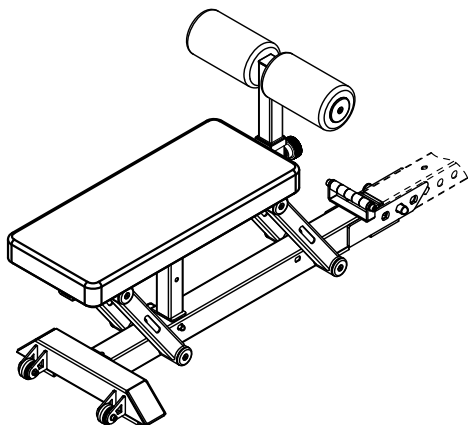
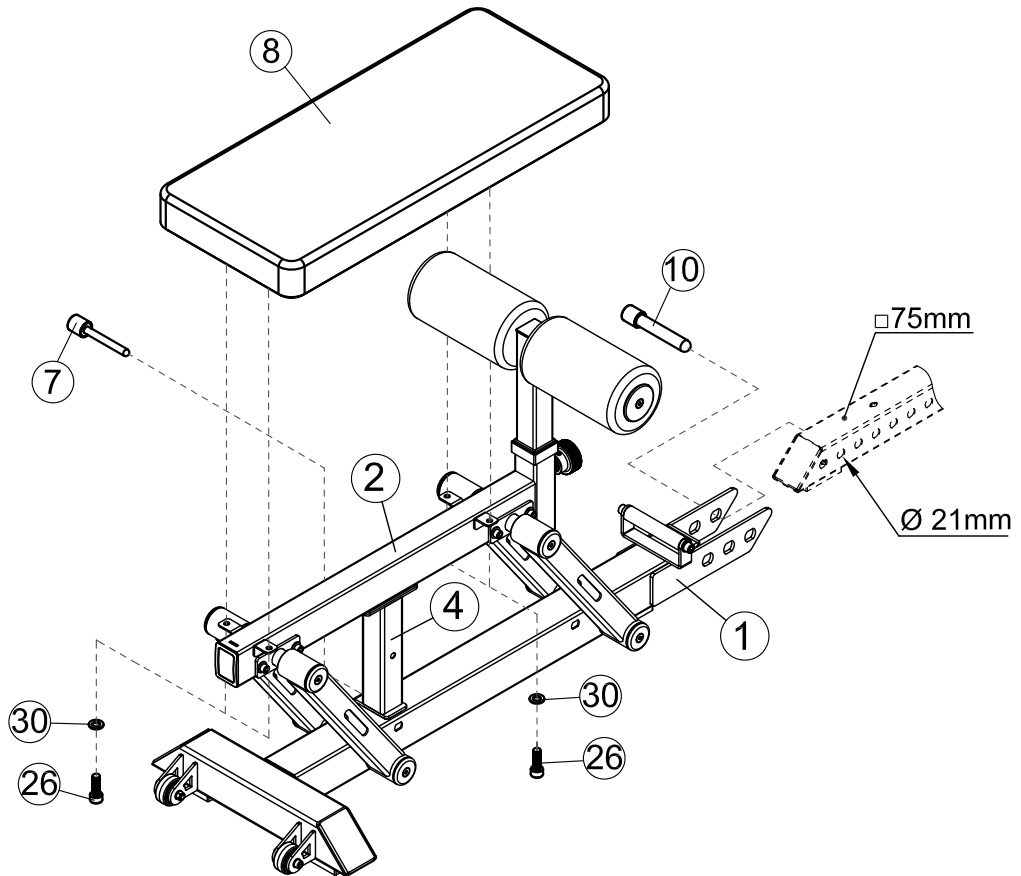
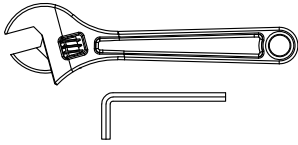

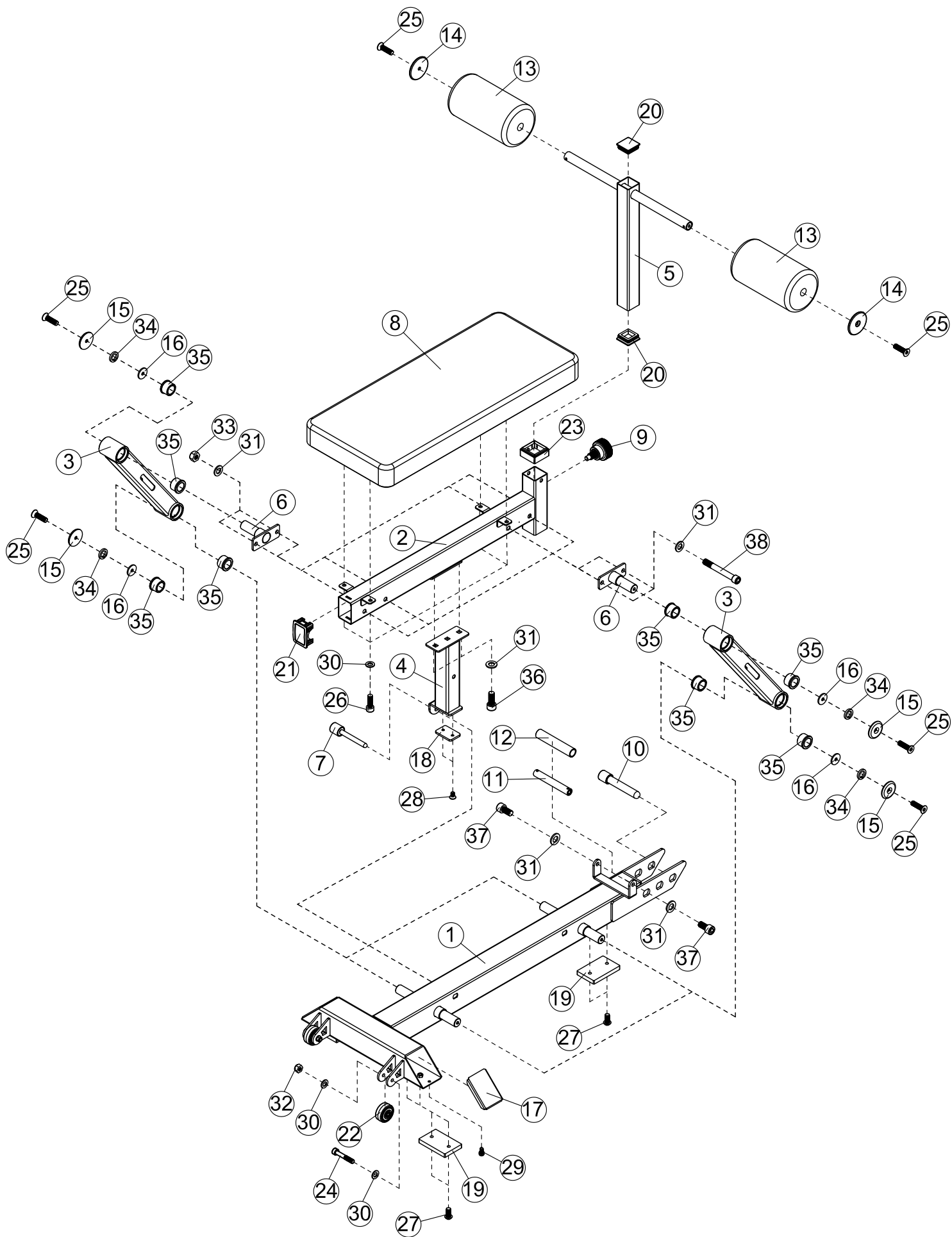

PARTS LIST

KEY NO.	PART DESCRIPTION	SPEC	QTY
1	Base Frame		1
2	Seat Support Frame		1
3	Cross Brace		4
4	Support Frame		1
5	FOAM Adjusting Frame		1
6	Cross Brace		4
7	Aluminum Alloy Bolt		1
8	Seat Pad	750×320×70	1
9	Aluminum alloy plug		1
10	Aluminum Alloy Bolt		1
11	Lined Tube		1
12	Handle tube	Φ25×2.5×130	1
13	FOAM	Φ125×Φ22×215	2
14	plate	Φ68×5.7	2
15	Aluminum Alloy End Cover	Φ50×Φ9×6	8
16	Inner Washer	Φ32×Φ9×3	8
17	Cover Cap	□75×2.5	2
18	Rack Liner	40×60×5	1
19	Rubber Stopper	65×100×12	3
20	Rectangular End Cap	□45	2
21	Rectangular End Cap	□50×70	1
22	Wheel	Φ50×28	2
23	Sleeve	□50×□45	1
24	Hexagon socket button head screws	M8×50	2
25	Hexagon socket countersunk head screws	M8×30	10
26	Hexagon socket button head screws	M8×25	4
27	Allen Bolt	M8×16	6
28	Hexagon socket countersunk head screws	M6×10	2
29	Hexagon socket button head screws	M5×10	2
30	Washer	8	8
31	Washer	10	12
32	Nut	M8	2
33	Nut	M10	4
34	Washer	8	8
35	Bushing	Φ38×Φ34×Φ25×22	16
36	Hexagon socket button head screws	M10×25	2
37	Hexagon socket button head screws	M10×20	2
38	Hexagon socket button head screws	M10×75	4
	Allen wrench	5#	1
	Allen wrench	6#	1
	Allen wrench	8#	1